

Conquest



ARGO 8x8

2018 PARTS MANUAL

8x8 Outfitter
Conquest XT
Conquest XT-D
Conquest XT-X
Conquest XT-L
Conquest XT-T

From Serial # ...40938 to 41044

**For factory installed accessory parts included with your vehicle see 2018 Conquest Accessories Manual*

Foreword

ODG has prepared this parts manual for the Conquest models to assist both qualified mechanics and vehicle owners in ordering correct, quality replacement ARGO parts. For the most current parts manual visit our website at www.argoxtv.com.

Proper and regular service, and replacing old, worn or broken parts with the correct ARGO replacement parts, are both essential to prolonging the life of the ARGO. Please refer to this parts manual and/or our website www.argoxtv.com before ordering any replacement part.

All information contained in this Conquest Parts Manual is based on the latest product specification available at time of printing. If your Conquest differs from the specifications contained in this manual, check our website www.argoxtv.com for the most current information.

ODG reserves the right to alter specifications on the Conquest models at any time, without obligation or prior notification.

Reproduction of this Conquest Parts Manual, in whole or in part, is prohibited without prior written permission from Ontario Drive & Gear Limited.

Vehicle Identification

Conquest - 2018 Serial Nos. beginning at ...40938 (last 5 digits of V.I.N.)

Explanation of Parts Manual Format

Ref - Reference number between assembly diagram and component parts list

Part No. - Argo replacement part number for identification and re-ordering

Description - Part description for identification and re-ordering

Qty - Indicates the quantity of a part used in an assembly

Conquest



Using the Parts Manual

1. Find the major vehicle assembly in the Table of Contents on this page, and turn to that section.
2. Locate the part in the illustration that you wish to order.
3. Refer to the parts list in that section.
4. Find the correct part number (Part No.), part description (Description) and correct quantity (Qty).
5. Use *only* this information to order ARGO replacement parts. **DO NOT** attempt to order a replacement part by reference number or page number.

Viewing Tip: To view manual on a computer monitor with images and parts list adjacent to each other (so you don't have to flip back and forth to match Ref. numbers): In Adobe Reader click View, Page Display, Two Page View/Two Page Scrolling.

Printing Tip: To print manual with images and parts list adjacent for convenient viewing, print pages 2 to 47 using a duplex printer. Click "Print on both sides of paper" box & "Flip on long edge". Then print Cover page separately.

Table of Contents

Foreword	i
Vehicle Identification.....	i
Using the Parts Manual	ii
Conquest Vehicle Accessory Matrix.....	iii
1.0 Upper Frame	2
2.0 Frame and Body.....	6
3.0 Axle Assembly	8
4.0 Chain Tensioners.....	9
5.0 Clutch System	10
6.0 Intake and Exhaust System.....	12
7.0 Power Pack Assembly	16
8.0 Transmission	20
8.1 Transmission Sub-Assemblies	22
9.0 Steering & Brake System	24
10.0 Parking Brake	26
11.0 Alternator.....	28
12.0 Fuel System & Seat Assembly	30
13.0 Electrical System.....	34
14.0 Outfitter Trim Package.....	40
15.0 XT-L Trim Package	42

Conquest Parts Manual

Conquest Vehicle Accessory Matrix

Old Model	XTi	XTd	Outfitter XTi	Explorer XTi	Lineman XTi	XTi
Model	Conquest 8X8 XT	Conquest 8X8 XT-Diesel	Conquest 8x8 Outfitter	Conquest 8X8 XT-X	Conquest 8X8 XT-L	Conquest 8X8 XT-T
Accessory						
Alternator	Yes	Yes	Yes	Yes	Yes	Yes
Bilge Pump	Yes	Yes	Yes	Yes	Yes	Yes
Brushguard	Yes	Yes	Yes	Yes	Yes	Yes
Build Package			Outfitter		XT-L	
Capstan						
Chain Lubrication	Yes	Yes	Yes	Yes	Yes	Yes
HD Drive Belt	Yes	Yes	Yes	Yes	Yes	Yes
Dump Box				Yes		
Engine	30 HP	24 HP Diesel	30 HP	30 HP	30 HP	30 HP
Entry Step			Rear			
Front Cargo Racks						
Gun Rack						
Headlights	Standard	Standard	LED Hi & Low	Standard	LED-Golight	Standard
Heated Hand Grips (Driver)			Yes	Yes		
Heater						
Mesh				Yes	Yes	
Rear Rack w/Toolbox (Tote)					Yes	
Receiver Winch						
Roof - Hard Top				Yes	Yes	
ROPS				2-Person	2-Person	
Seats	Standard	Standard	Deluxe	Standard	Standard	Standard
Skid Plate	Yes	Yes	Yes	Yes	Yes	Yes
Spot Light						
Stretcher					Yes	
Strobe Light						
Tires	25 Offset Stl Rim	25 Offset Stl Rim	25 Offset Stl Rim	25 Offset Stl Rim	25 Offset Stl Rim	24 HD Turf Tires
Transmission	Std Admiral	Std Admiral	Std Admiral	Std Admiral	Std Admiral	Std Admiral
Vice					Yes	
Winch - Front	Yes	Yes	Yes	Yes	Yes	Yes
Windshield				Yes	Yes	
Wiper Kit				Yes	Yes	

1.0 Upper Frame - XT

Conquest Parts Manual

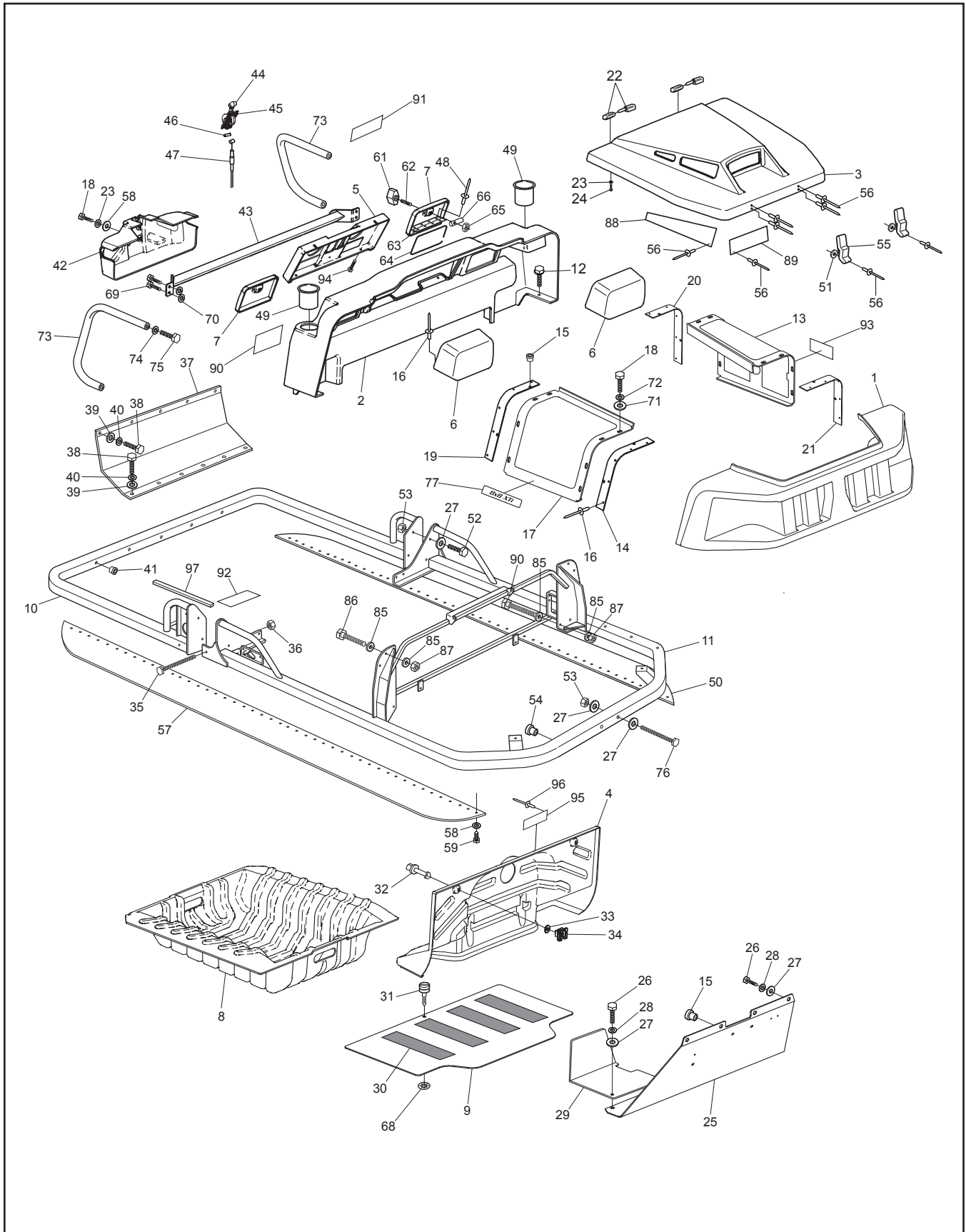

Conquest Parts Manual

1.0 Upper Frame - XT

Ref.	Qty.	Part #	Description	Ref.	Qty.	Part #	Description
1	1	951-01	Body, Upper Nose - XT**	51	4	120-05	Washer .19x.50x.04 Zn
2	1	951-02	Body, Upper Dash - XT**	52	4	112-93	HHCS M10 x 1,5 x 25mm
3	1	951-03	Hood, XT**	53	6	117-60	Locknut, Nyloc M10 x 1.5mm Zn
4	1	951-04	Firewall - XT	54	4	117-70	Insert, M10 x 1.5-13.5mm OD
5	1	951-06	Panel, Dash Console - XT	55	2	602-56	Latch, Hood - Soft Draw
6	2	951-07	Glovebox - XT	56	22	120-11	Rivet, 5/32 x .157-.472
7	2	951-08	Cover, Glovebox - XT	57	1	801-195	Mud Flap, 7" Wide XT, RH
8	1	951-12	Floorpan, XT	58	98	108-08	Washer .28 x .62 x .04 Zn
9	1	953-05	Floor Plate, Front, XT	59	94	112-125	Screw, Self-Drilling 12-14 x 1.5" Zn
10	1	950-33	Upper Frame, Rear Weldt - XT	60	8	120-14	Rivet - 3/16 x 5/8 Black
11	1	950-06	Upper Frame Weldt, XT	61	2	126-104	Knob, 2 Arm, 1/4"-20 Insert
12	10	112-204	Screw, Self Drilling 12-14x1	62	2	126-105	Stud, 1/4-20 x 1.75 Lg
13	1	950-40	Screen Ass'y - LH XT	63	2	126-106	Hinge, Plastic, 1-1/2x6-1/2
14	1	952-233	Bracket, Screen Ass'ySupport - RH FR	64	2	126-107	Seal, Bulb, XT Glovebox
15	22	117-79	Insert, M6 x 1,0 -10mm OD	65	2	117-102	Nut, Jam, 1/4-20
16	20	120-13	Rivet - 3/16 X 3/4 Black	66	2	953-34	Pin, Glovebox Catch, XT
17	1	950-41	Screen Ass'y - RH XT	67	2	117-27	Locknut, Nylon 1/4-20 Zn
18	12	112-212	HHCS M6 x 1,0 x 25mm Black Zn	68	1	127-120	Retainer, Fast Lead Screw - Large
19	1	952-234	Bracket, Screen Ass'y Support - RH RR	69	4	112-63	HHCS M8x1,25x35mm Gr5 Zn
20	1	952-232	Bracket, Screen Ass'y Support - LH RR	70	4	117-77	Locknut, Nylon - M8x1,25mm Zn8
21	1	952-231	Bracket, Screen Ass'y Support - LH FR	71	22	108-104	Washer, 0.28 ID x 1.0 OD x 0.13, Black
22	2	127-88L	Hinge, Engine Cover	72	22	108-105	Lockwasher, 1/4 Split, Blk Zn
23	12	108-03	Lockwasher 1/4 Split Ring Zn	73	2	953-33	Handle, Grab, XT
24	8	112-220	HHCS M6 x 1,0 x 20mm	74	4	108-35	Washer .53x1.06x.09 Zn
25	1	953-04	Support, Front, XT	75	4	112-151	HHCS 1/2-13x1" Gr2 Zn
26	10	112-133	HHCS M10 x 1,5 x 35mm Zn	76	2	112-120	HHCS M10x1,5x80mm Zn
27	14	108-15	Washer .42 x .81 x .05 Zn	77	2	850-392	Nameplate, Conquest XTi
28	10	108-67	Lockwasher M10 Split-Ring Zn	2	850-396	Nameplate, Outfitter XTi	
29	1	850-227	Shield, Alternator XT	2	850-397	Nameplate, Outfitter XTi-Z	
30	4ft	127-183RM	Tape, Non-Slip-4 WD x 60ft LG	2	850-398	Nameplate, Lineman XTi	
31	1	112-136	Screw, Fastlead - Large	2	850-404	Nameplate, Conquest 8x8 i	
32	2	112-312	Stud, Q-Turn 6mm x 15mm Stl	85	16	108-102	Washer, 0.67x1.18x0.12, Zn*
33	2	114-40	Washer, Stud Retainer 6mm	86	4	112-208	HHCS M16x2x50mm GrZn*
34	2	117-126	Clip, Q-Turn 6mm - Steel	87	4	117-76	Locknut, Nylon M16x2,0 Zn*
35	2	112-205	HHCS M12 x 1.75 x 80mm Zn	88	2	953-30	Screen, Side Hood, XT
36	2	112-206	Locknut, Nylon, M12 x 1.75 Zn	89	1	953-31	Screen, Front Hood, XT
37	1	953-41	Brace, Rear - XT	90	1	126-68	Plate, Operation
38	11	112-20	HHCS M8 x 1,25 x 25mm Zn	91	1	127-238	Label, Capacity - XTi
39	11	108-24	Washer .34 x .70 x .06 Zn	92	1	126-69	Plate, Fuel
40	11	108-05	Lockwasher 5/16 Split-Ring	93	1	127-144	Label, Warning HOT
41	5	117-69	Insert, M8x1.25-13.5 mm OD	94	4	112-182	HHCS 10-24 x .75 Zn
42	1	951-05	Cover, Steering Assembly - XT	95	1	129-01	Plate, Geared By ODG
43	1	950-10	Weldt, Steering Bar	96	4	120-13	Rivet - 3/16 x 3/4 Black
44	1	127-212	Pivot, Hi-Lo Shifter	97	.5	953-96RM	Trim, Neoprene W/Glue
45	1	127-211	Bracket, Hi-Lo Shifter				* If equipped
46	1	104-66	Pin, HD Shift Cable Threaded				** Specify colour
47	1	127-223	Cable, Hi-Lo Shift Threaded				
48	16	120-09	Rivet - 3/16 x 1.0 Black				
49	2	100-109	Cup Holder Insert				
50	1	801-196	Mud Flap, 7" Wide XT, LH				

1.0 Upper Frame - XT Diesel

Conquest Parts Manual

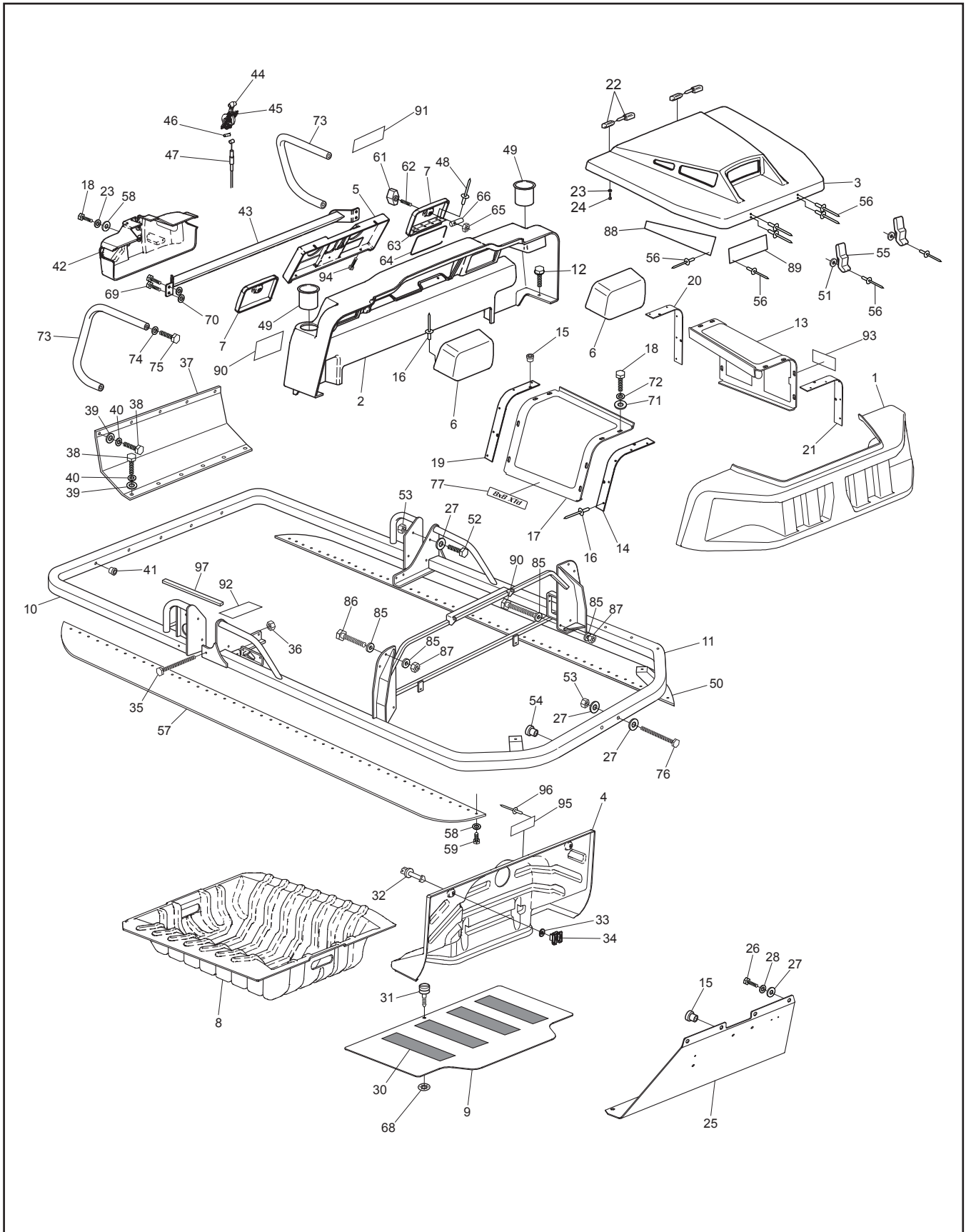

Conquest Parts Manual

1.0 Upper Frame - XT Diesel

Ref.	Qty.	Part #	Description	Ref.	Qty.	Part #	Description
1	1	951-01	Body, Upper Nose - XT**	52	4	112-93	HHCS M10 x 1,5 x 25mm
2	1	951-02	Body, Upper Dash - XT**	53	6	117-60	Locknut, Nyloc M10x1.5mm Zn
3	1	951-03	Hood, XT**	54	4	117-70	Insert, M10 x 1.5-13.5mm OD
4	1	951-04	Firewall - XT	55	2	602-56	Latch, Hood - Soft Draw
5	1	951-06	Panel, Dash Console - XT	56	22	120-11	Rivet, 5/32 x .157-.472
6	2	951-07	Glovebox - XT	57	1	801-195	Mud Flap, 7" Wide XT, RH
7	2	951-08	Cover, Glovebox - XT	58	98	108-08	Washer .28 x .62 x .04 Zn
8	1	951-12	Floorpan, XT	59	94	112-125	Screw, Self-Drilling 12-14 x 1.5" Zn
9	1	953-05	Floor Plate, Front, XT	60	8	120-14	Rivet - 3/16 x 5/8 Black
10	1	950-33	Upper Frame, Rear Weldt XT	61	2	126-104	Knob, 2 Arm, 1/4"-20 Insert
11	1	950-06	Upper Frame Weldt, XT	62	2	126-105	Stud, 1/4-20 x 1.75 Lg
12	10	112-204	Screw, Self Drilling 12-14x1	63	2	126-106	Hinge, Plastic, 1-1/2x6-1/2
13	1	950-40	Screen Ass'y - LH XT	64	2	126-107	Seal, Bulb, XT Glovebox
14	1	952-233	Bracket, Screen Ass'ySupport - RH FR	65	2	117-102	Nut, Jam, 1/4-20
15	22	117-79	Insert, M6 x 1,0 -10mm OD	66	2	953-34	Pin, Glovebox Catch, XT
16	20	120-13	Rivet - 3/16 X 3/4 Black	67	2	117-27	Locknut, Nylon 1/4-20 Zn
17	1	950-41	Screen Ass'y - RH XT	68	1	127-120	Retainer, Fast Lead Screw - Large
18	12	112-212	HHCS M6 x 1,0 x 25mm Black Zn	69	4	112-63	HHCS M8x1,25x35mm Gr5 Zn
19	1	952-234	Bracket, Screen Ass'y Support - RH RR	70	4	117-77	Locknut, Nylon - M8x1,25mm Zn8
20	1	952-232	Bracket, Screen Ass'y Support - LH RR	71	22	108-104	Washer, 0.28 ID x 1.0 OD x 0.13, Black
21	1	952-231	Bracket, Screen Ass'y Support - LH FR	72	22	108-105	Lockwasher, 1/4 Split, Blk Zn
22	2	127-88L	Hinge, Engine Cover	73	2	953-33	Handle, Grab, XT
23	12	108-03	Lockwasher 1/4 Split Ring Zn	74	4	108-35	Washer .53x1.06x.09 Zn
24	8	112-220	HHCS M6 x 1,0 x 20mm	75	4	112-151	HHCS 1/2-13x1" Gr2 Zn
25	1	953-04	Support, Front, XT	76	2	112-120	HHCS M10x1,5x80mm Zn
26	8	112-133	HHCS M10 x 1,5 x 35mm Zn	77	2	850-393	Nameplate, Conquest XTd
27	12	108-15	Washer .42 x .81 x .05 Zn	2	2	850-395	Nameplate, Explorer XTd
28	8	108-67	Lockwasher M10 Split-Ring Zn	2	2	850-405	Nameplate, Conquest 8x8 d
30	4ft	127-183RM	Tape, Non-Slip-4 WD x 60ft LG	85	24	108-102	Washer, 0.67x1.18x0.12, Zn*
31	1	112-136	Screw, Fastlead - Large	86	4	112-208	HHCS M16x2x50mm Gr Zn*
32	2	112-312	Stud, Q-Turn 6mm x 15mm Stl	87	8	117-76	Locknut, Nylon M16x2,0 Zn*
33	2	114-40	Washer, Stud Retainer 6mm	88	2	953-30	Screen, Side Hood, XT
34	2	117-126	Clip, Q-Turn 6mm - Steel	89	1	953-31	Screen, Front Hood, XT
35	2	112-205	HHCS M12 x 1.75 x 80mm Zn	90	4	112-207	HHCS M16x2x70mm Gr8.8 Zn
36	2	112-206	Locknut, Nylon, M12 x 1.75 Zn	90	1	126-68	Plate, Operation
37	1	953-41	Brace, Rear - XT	91	1	127-291	Label, Capacity - XTD
38	11	112-20	HHCS M8 x 1,25 x 25mm Zn	92	1	127-294	Label, Diesel Fuel Only
39	11	108-24	Washer .34 x .70 x .06 Zn	93	1	127-144	Label, Warning HOT
40	11	108-05	Lockwasher 5/16 Split-Ring	94	4	112-182	HHCS 10-24 x .75 Zn
41	5	117-69	Insert, M8x1.25-13.5 mm OD	95	1	129-01	Plate, Geared By ODG
42	1	951-05	Cover, Steering Assembly - XT	96	4	120-13	Rivet - 3/16 x 3/4 Black
43	1	950-10	Weldt, Steering Bar	97	.5	953-96RM	Trim, Neoprene W/Glue
44	1	127-212	Pivot, Hi-Lo Shifter				
45	1	127-211	Bracket, Hi-Lo Shifter				
46	1	104-66	Pin, HD Shift Cable Threaded				
47	1	127-223	Cable, Hi-Lo Shift Threaded				
48	16	120-09	Rivet - 3/16 x 1.0 Black				
49	2	100-109	Cup Holder Insert				
50	1	801-196	Mud Flap, 7" Wide XT, LH				
51	4	120-05	Washer .19x.50x.04 Zn				

* If equipped
** Specify colour

2.0 Frame and Body

Conquest Parts Manual

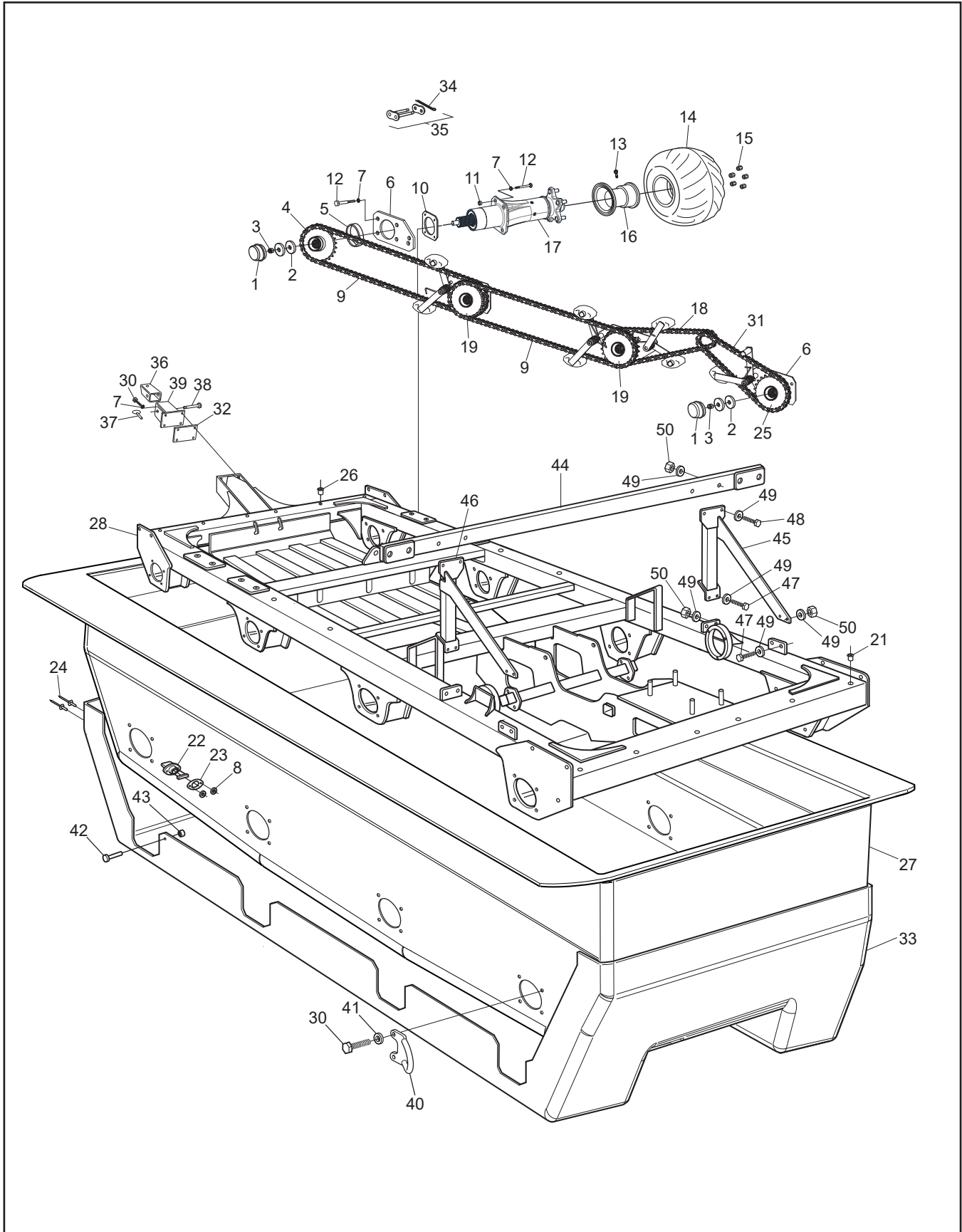

Ref.	Qty.	Part #	Description
1	8	805-120	Cap, Bearing Dust - 2.0 Plated
2	16	108-40	Washer .68 x 1.77 x .16 Zn
3	8	117-72	Locknut, Nylon - M16 x 1,5 Zn
4	2	805-136	Sprocket Asm, Rear -S60 x 24T
5	8	805-108	Bushing, 1.97 Od, 1.82 Id x .46
6			See Section 5.0 Chain Tensioners
7	68	108-67	Lockwasher M10 Split Ring Zn
8	4	120-04	Washer .19 x .50 x .08 Zn
9	4	953-16	Chain, RC60-1-HD X 96P
10	8	805-121	Gasket, Flange
11	32	805-114	Bushing .75 x .58 x .25 Zn
12	60	112-133	HHCS M10 x 1,5 x 35mm Zn
13	8	125-26	Valve, Tire
14	8	127-182	Tire, Argo 25 x 12-9
15	40	117-74	Nut, Wheel M12 x 1,25 Zn
16	8	127-61BL	Rim - 10 x 9 -Black
17	8	805-133	Axle Asm, Centaur/XT
18	2	953-15	Chain, RC60-1-HD x 58P
19	4	805-135	Sprocket Asm, Mid - S60 x 2 x 24T
20		126-60	Vinyl Strip 1/2" x 1/4"
21	10	117-70	Insert, M10 x 1.5-13.5mm OD
22	2	100-107	Plug, Drain - Flanged
23	2	100-114	Gasket, Drain Plug
24	4	120-09	Rivet 3/16 x 1 - Black
25	2	805-137	Sprocket Asm, Front - S60 x 24T
26	6	117-69	Insert, M8 x 1.25-13.5mm OD
27	1	951-15	Body, Lower - XTI
28	1	950-05	Frame Asm, XTI
	1	950-38	Frame, Chassis - XTD
	1	958-274	Wldt, Frame, Outfitter
29		953-32	Link, 2P Offset, RC60HD
30	8	112-92	HHCS M10 x 1,5 x 40mm Zn
31	2	953-14	Chain, RC60-1-HD x 54P
32	1	616-20	Gasket, Rear Hitch
33	1	801-123SKD	Skid Plate - Centaur
34		100-116	Pin, Cotter - .09 x .63
35		953-12	Link, RC60-1-HD, Slip Fit
36	1	616-19	Tube, Hitch
37	1	104-11	Pin, Lynch
38	1	104-13	Pin, Top Link
39	1	616-16	Hitch Draw Bar Assembly
40	2	642-84	Tie Down
41	8	108-15	Washer .42x.81x.05 Zn
42	36	120-27	Pin, Magna Grip, Black Zn
43	36	120-28	Collar, Magna Grip Zinc Dichro
44	1	956-04	Support, ROPS, Horizontal
45	1	956-05	Support, ROPS Vertical, LH
46	1	956-06	Support, ROPS Vertical, RH
47	4	112-93	HHCS M10 x 1,5 x 25mm
48	4	112-22	HHCS M10 x 1,5 x 35mm
49	24	108-101	Washer, 10mm, DIN125A
50	12	117-60	Locknut, Nyloc M10 x 1.5mm Zn8
51	8	117-76	Locknut, Nylon - M16 x 1.5 Zn

3.0 Axle Assembly

Conquest Parts Manual

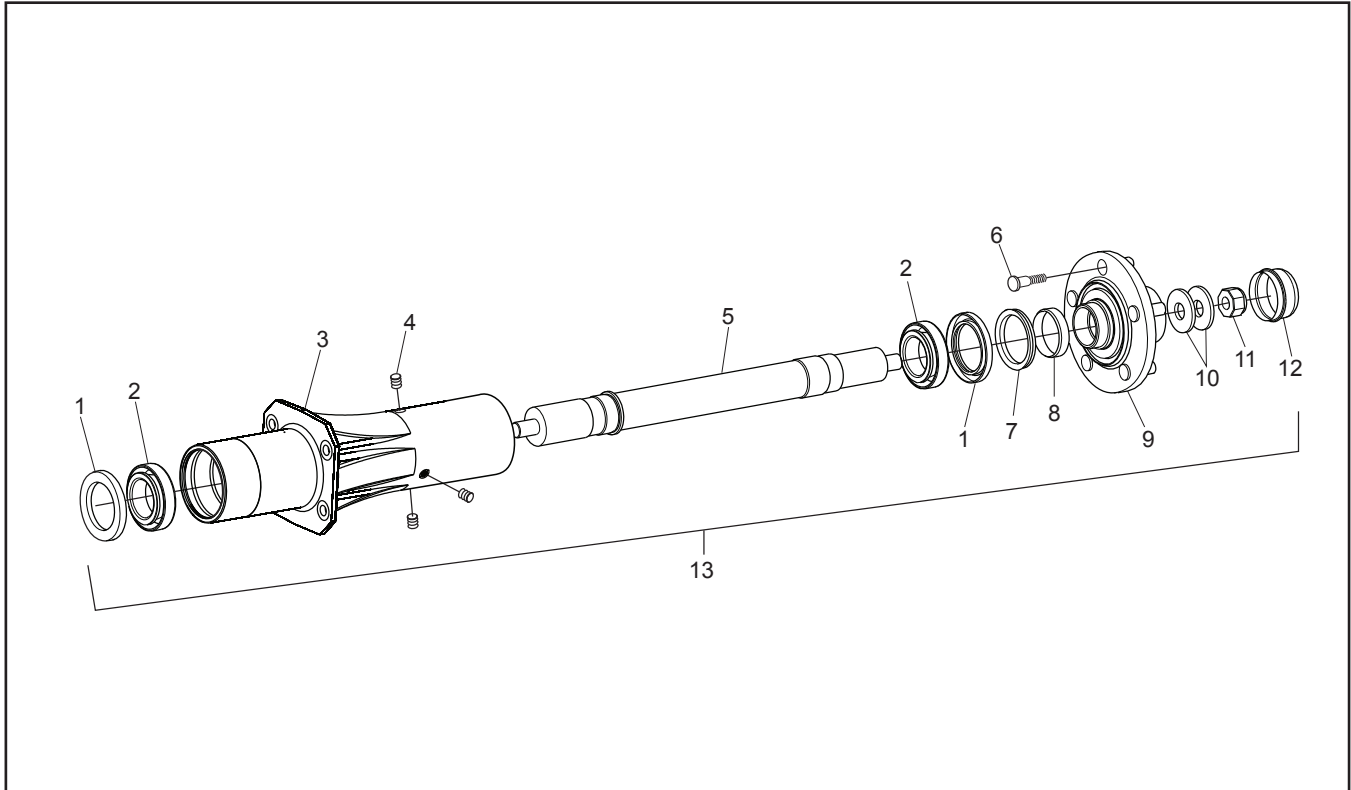

Ref.	Qty.	Part #	Description
1	2	102-27	Seal, Oil 50x72x8 Dbl Lip
2	2	101-76	Bearing, Tapered Roller 32008X
3	1	805-132	Housing Asm, Axle
4	3	127-85	Plug, Drain - M10 x 1,0
5	1	805-106	Axle -17T Spline
6	5	112-81	Stud, Wheel - M12 x 1,25R Zn
7	1	102-28	Seal, Oil V-ring 50mm
8	1	805-108	Bushing, 1.97 OD, 1.82 ID x .46
9	1	805-107	Hub, Wheel
10	2	108-40	Washer .68x1.77x.16 Zn
11	1	117-72	Locknut, Nylon - M16 x 1,5 Zn
12	1	805-120	Cap, Bearing Dust - 2.0 Plated
13	8	805-133	Axle Ass'y

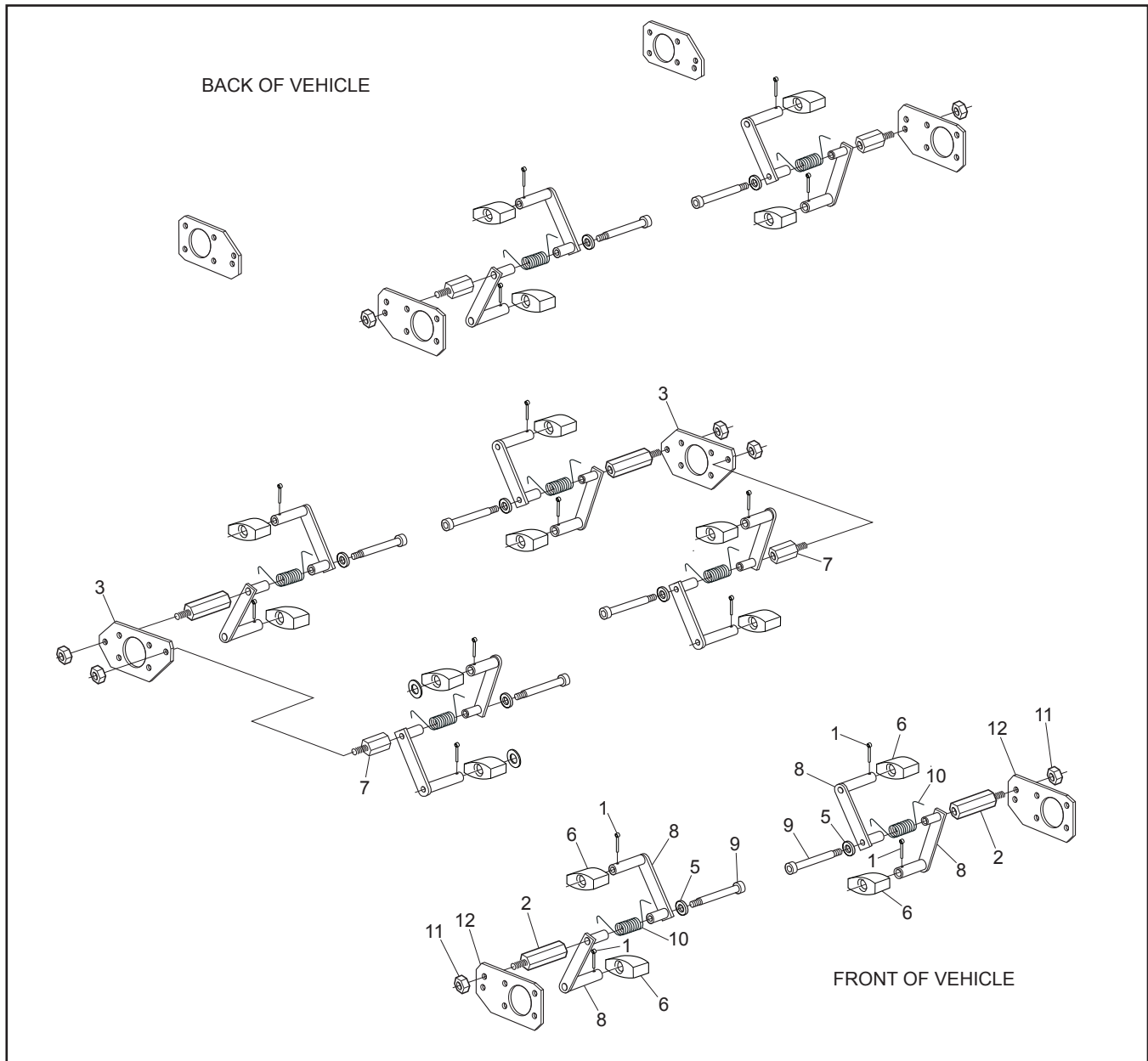

Ref.	Qty.	Part #	Description
1	16	100-105	Pin, Cotter 3/16 x 1.75" Zn
2	4	953-19	Standoff, Hex, 54mm
3	2	953-22	Flange, 2 Pos., XT
5	24	108-34	Washer .47 x .94 x .06 Zn
6	16	606-40	Slider Block -7/8" Shaft
7	4	953-20	Standoff, Hex, 23.5mm
8	16	806-211	Pivot Arm Asm
9	8	112-158	Bolt, Shoulder, 12mm x 70mm Lg
10	8	128-16	Spring, Torsion - Cent. Chain
11	8	117-32	Locknut, Nylon 7/16-20 Zn
12	6	953-21	Flange, Axle, XT

5.0 Clutch System - XT

Conquest Parts Manual

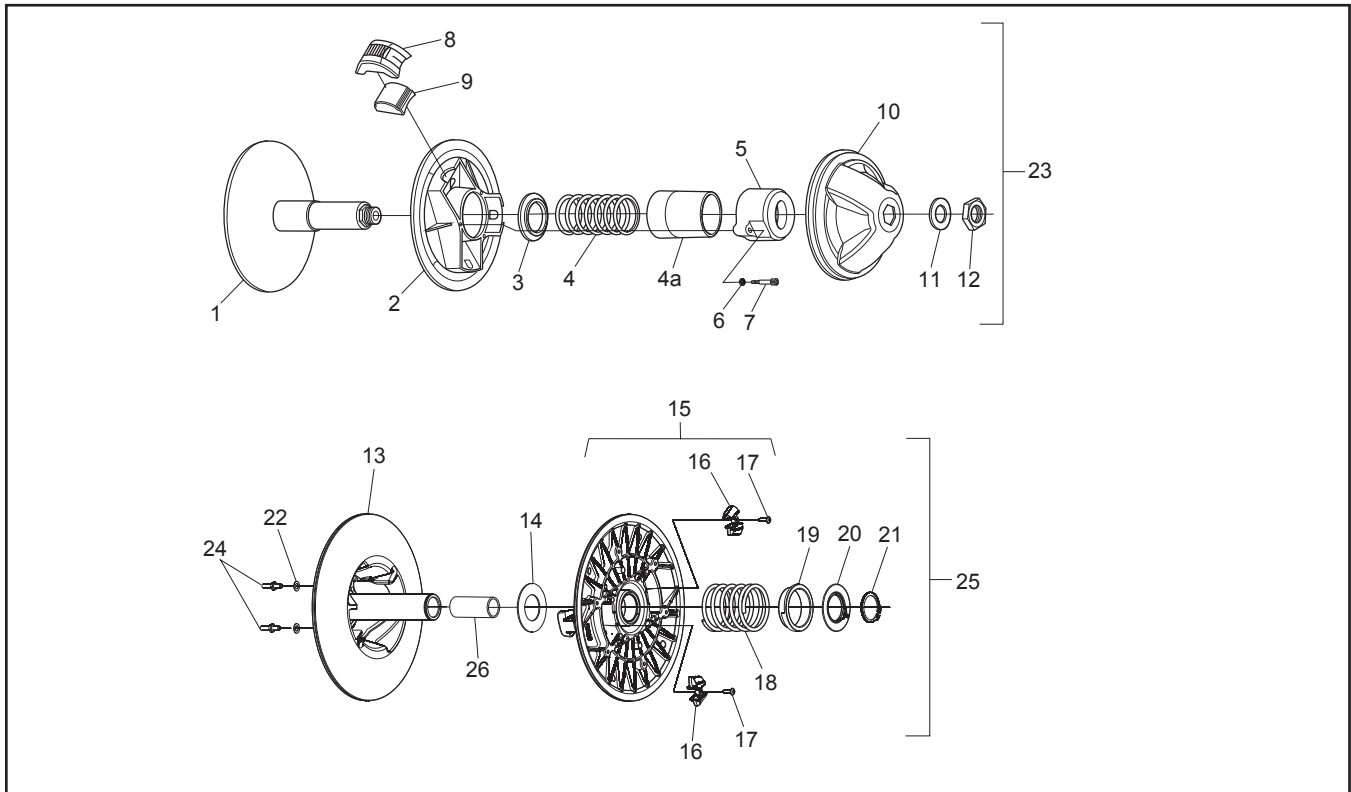

Ref.	Qty.	Part #	Description
1	1	0405-0138	Flange, Fixed
2	1	0410-0033	Flange, Sliding
3	1	0150-1014	Spring Guide Washer
4	1	1151-1114	Spring
4a	1	0450-3002	Guide, Spring
5	1	0440-0005	Spring Cover
6	3	0080-0167	Lockwasher
7	3	0080-0021	Screw, Cap
8	3	0130-3012	Block
9	3	0135-3061	Weight (230gr) - EFI Model
	1	127-208	Weight Set (3), 185g - High Elevation
	1	127-209	Weight Set (3), 220g - High Elevation
	1	127-210	Weight Set (3), 240g - High Elevation
10	1	0115-2061	Cap
11	1	0080-0804	Washer, Zn
12	1	V16J1	Nut
13	1	5905-0003	Flange, Fixed
14	1	0080-0164	Washer, Shim
15	1	5910-0002	Flange, Sliding
16	3	5930-3001	Cam Shoe
17	2	0080-0031	Screw
18	1	5951-1009	Spring
19	1	5950-3003	Spring Protector
20	1	5950-3002	Spring Support
21	1	0080-0216	Retaining Ring, Outside
22	2	0080-0167	Lockwasher
23	1	610-128	Clutch, Driver - EFI Models
24	2	0080-0035	Screw & Nut Ass'y
25	1	127-156	Clutch, Driven - INVANCE
26	1	5940-2001	Keyway Stopper

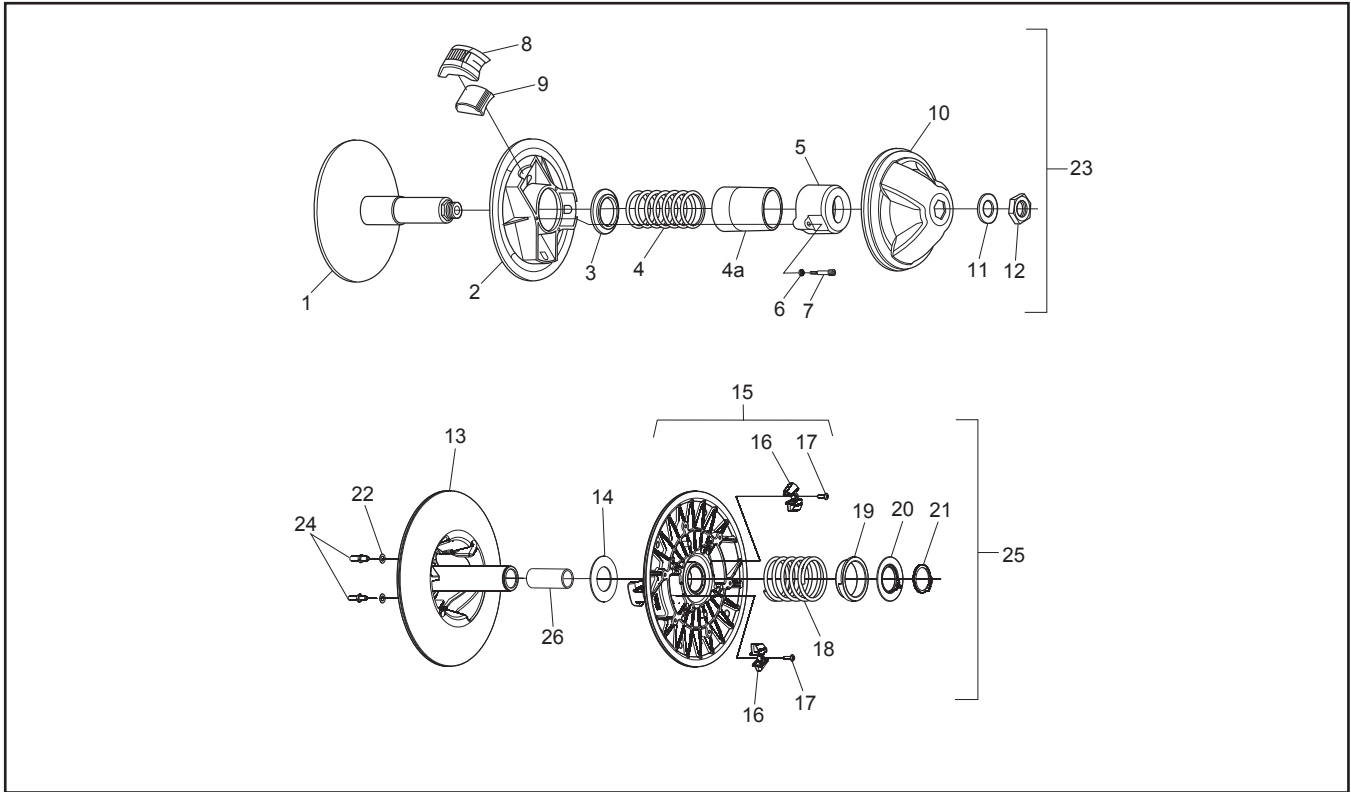

Ref.	Qty.	Part #	Description
1	1	0405-0137	Flange, Fixed
2	1	0410-0033	Flange, Sliding
3	1	0150-1014	Spring Guide Washer
4	1	1151-1110	Spring
4a	1	0450-3002	Guide, Spring
5	1	0440-0005	Spring Cover
6	3	0080-0167	Lockwasher
7	3	0080-0021	Screw, Cap
8	3	0130-3012	Block
9	3	0135-3064	Weight (260gr)
	1	127-208	Weight Set (3), 185g - High Elevation
	1	127-209	Weight Set (3), 220g - High Elevation
	1	127-210	Weight Set (3), 240g - High Elevation
10	1	0115-2061	Cap
11	1	0080-0804	Washer, Zn
12	1	V16J1	Nut
13	1	5905-0003	Flange, Fixed
14	1	0080-0164	Washer, Shim
15	1	5910-0002	Flange, Sliding
16	3	5930-3001	Cam Shoe
17	2	0080-0031	Screw
18	1	5951-1009	Spring
19	1	5950-3003	Spring Protector
20	1	5950-3002	Spring Support
21	1	0080-0216	Retaining Ring, Outside
22	2	0080-0167	Lockwasher
23	1	610-130	Clutch, Driver - XTD
24	2	0080-0035	Screw & Nut Ass'y
25	1	127-156	Clutch, Driven - INVANCE
26	1	5940-2001	Keyway Stopper

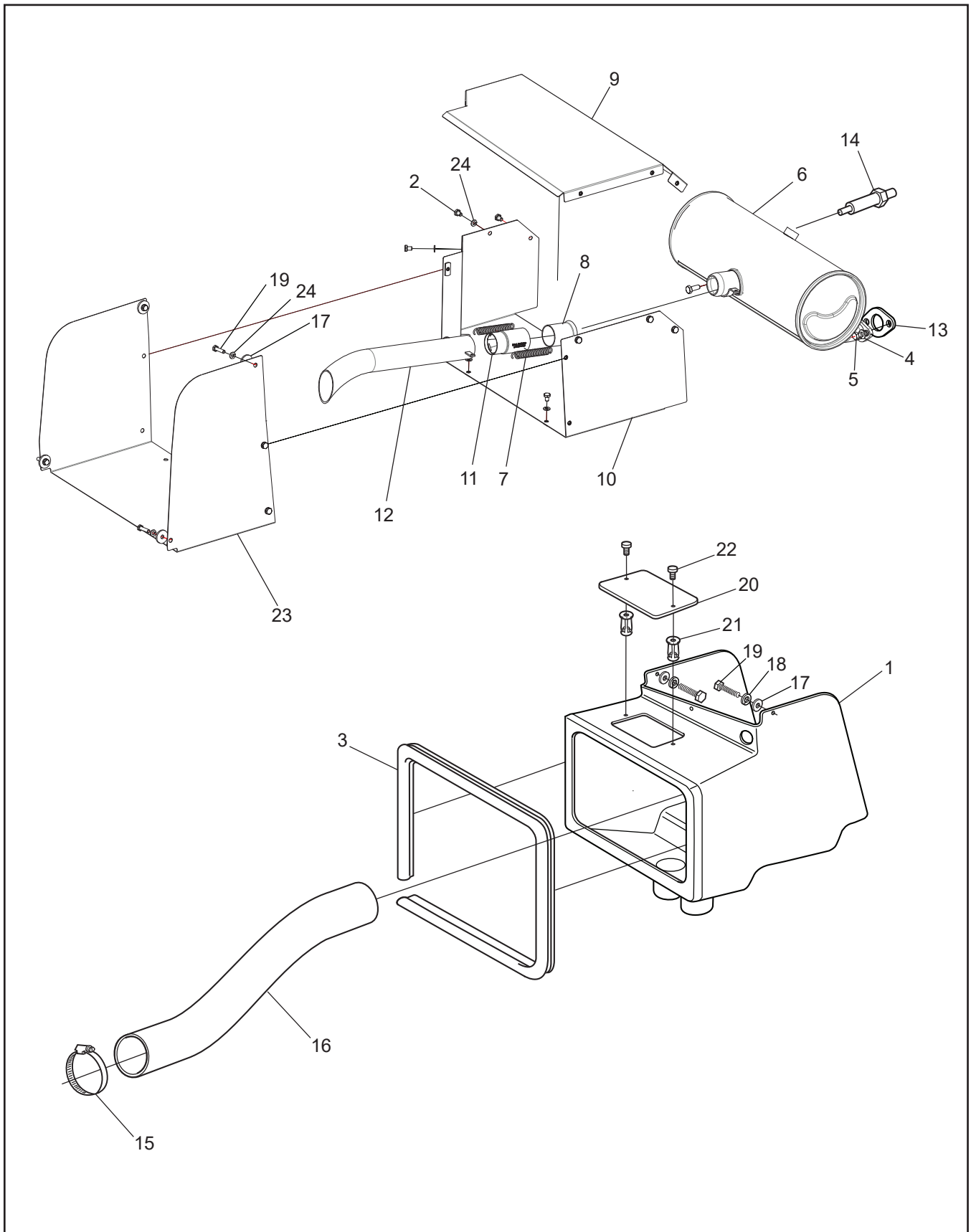

Ref.	Qty.	Part #	Description
1	1	951-13	Duct, Intake
2	12	112-315	H.H.C.S. 1/4 - 20 x 3/8 BNZ
3	2	809-166-50	Seal, 50" Long
4	4	108-24	Washer, .34x.70x.06
5	4	112-111	HHCS M8x1,25x20 (8.8)
6	1	607-212	Muffler, Kohler Aegis, EES
7	2	127-187	Spring, Extension - 17/32 x 3.75
8	1	607-135	Tube, Muffler, Flared x 2.0
9	1	953-99	Duct, Conquest Exhaust - Cover
10	1	953-98	Duct, Conquest Exhaust - Muffler
11	1	607-171	Spark Arrestor, ODG
12	1	607-134	Pipe, Tail - Ass'y
13	2	24 041 49	Gasket, Exhaust Manifold
14	1		See Section 7.0 Power Pack Assembly
15	1	100-128	Clamp, Gear 2.25"
16	1	848-194	Hose, Intake Flex 2" Dia. x 24"
17	4	108-104	Washer, 0.28ID x 1.0OD x 0.13, Blk
18	4	108-105	Lockwasher, 1/4 Split, Blk Zn
19	4	112-212	HHCS M6 x 1 x 25mm, Black Zn
20	1	952-237	Cover, Cleanout XT
21	2	117-53	Nut, Jack 1/4-20 8L-JNS Zn
22	2	117-89	Thumbscrew, 1/4-20x1, Nylon
23	1	953-97	Duct, Conquest Exhaust - Body
24	16	108-03	Lockwasher, 1/4 Split Ring

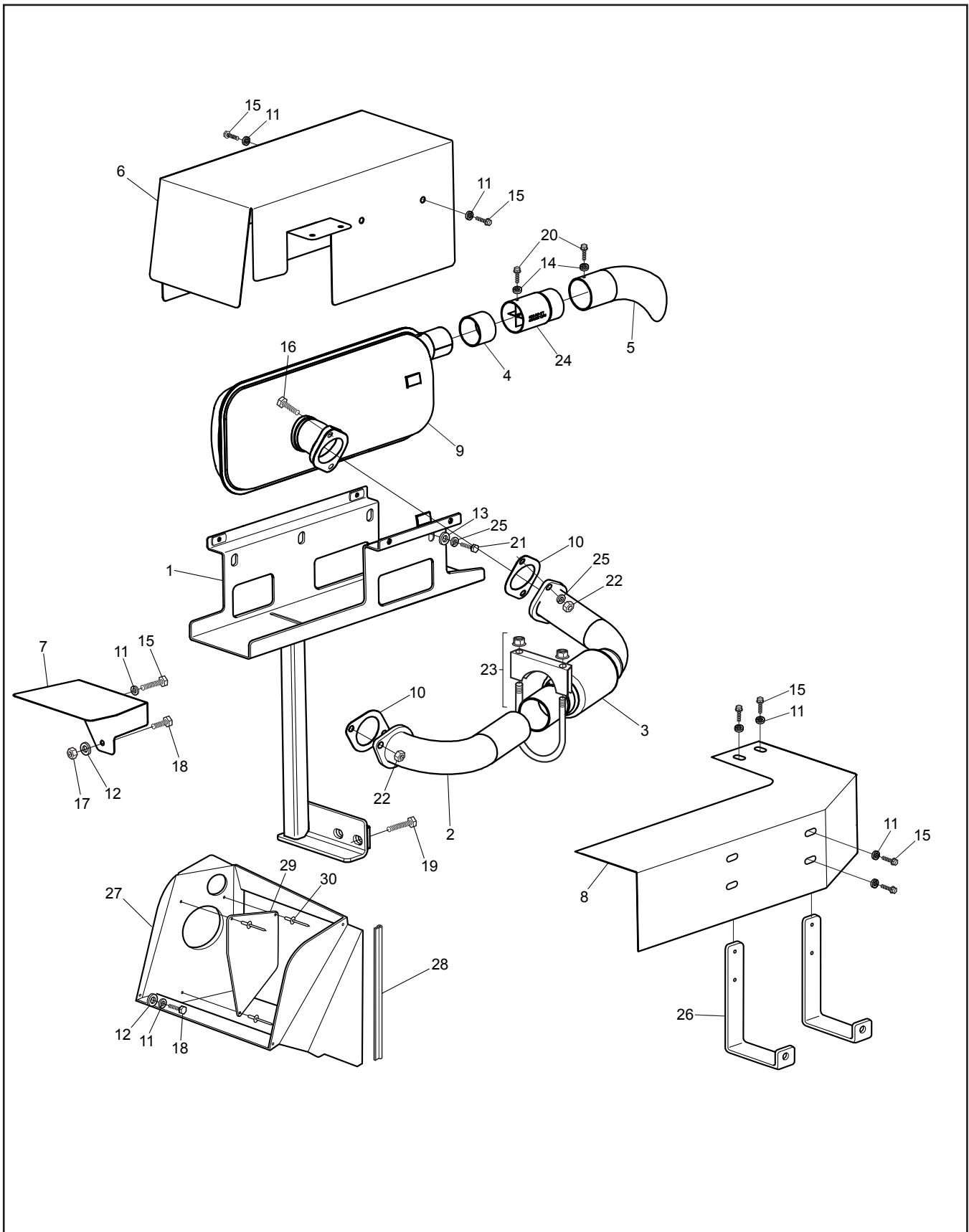

Ref.	Qty.	Part #	Description
1	1	950-42	Wldmt, Muffler Support XTD
2	1	950-44	Wldmt, Exhaust Engine XTD
3	1	950-45	Wldmt, Exhaust Muffler XTD
4	1	952-252	Tube, 1-5/8 OD x 1-1/8
5	1	952-253	Pipe, Tail 60 Deg x 5.5
6	1	953-70	Duct, Exhaust XTD
7	1	953-82	Shield, Oil Filter XTD
8	1	953-93	Shield, Exhaust XTD
9	1	953-88	Muffler, Kohler XTD
10	2	953-89	Gasket, Exhaust Flange XTD
11	14	108-03	Lockwasher 1/4 Split Ring Zn
12	4	108-08	Washer .28x.62x.07 Zn
13	4	108-24	Washer .34x.70x.06 Zn
14	2	108-86	Lockwasher #10 Ext Tooth Zn
15	11	112-19	Screw, IHWH T/C Slot 1/4-20x1/2
16	2	112-20	HHCS M8x1,25x25mm Zn
17	1	112-115	Locknut, Nylon M6x1 Zn
18	4	112-118	HHCS M6x1,0x15mm
19	2	112-133	HHCS M10x1,5x35mm Zn
20	2	112-168	Screw, IHWH #10 x 3/8
21	4	112-234	HHCS M8x1,25x12mm Zn
22	4	117-73	Nut M8x1,25 Zn
23	1	607-195	Clamp, Muffler 1-7/8" Dia
24	1	607-171	Spark Arrestor, ODG
25	6	108-05	Lockwasher 5/16 Split Ring
26	2	953-94	Bracket, Exhaust Shield XTD
27	1	950-46	Intake Plenum - XTD
28	4	809-167RM	Seal, Radiator Baffle - Top 14.5" Long
29	1	953-79	Cover, Intake Plenum - XTD
30	3	120-13	Rivet - 3/16 x 3/4 Black
31	1	953-95	Bracket, Exhaust - XTD

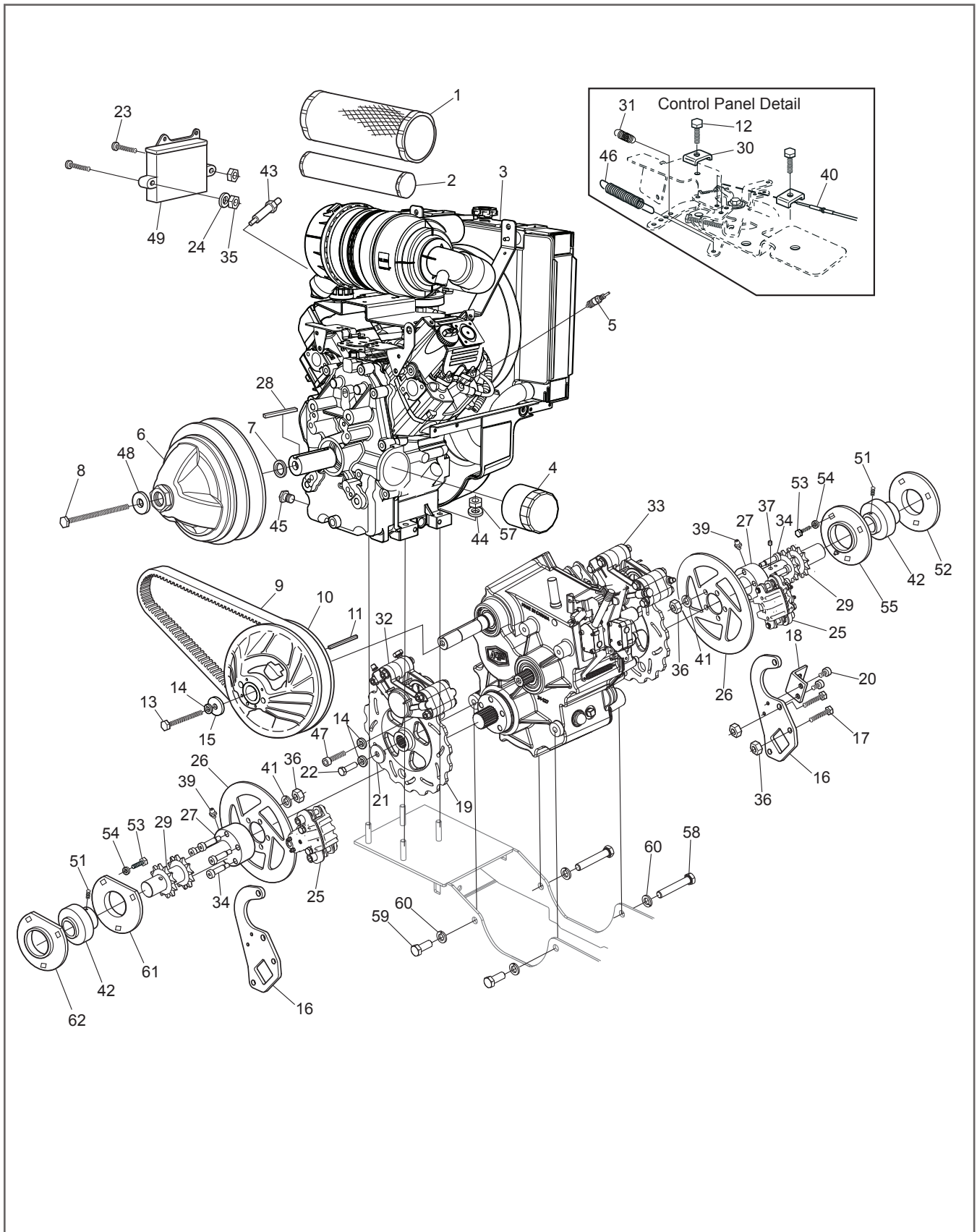

Ref.	Qty.	Part #	Description	Ref.	Qty.	Part #	Description
1	1	25 083 01	Filter, Air	37	1	613-127	Magnet, Speedometer
2	1	25 083 04	Element, Inner	39	2	100-127	Fitting, Grease STR 1/4-28 TPR
3	1	ELH775-3011	Kohler 30 HP Engine, EFI	40	1	612-135	Cable Asm., Throttle, XT
4	1	12 050 01	Filter, Oil	41	11	108-05	Lockwasher 5/16 Split- Ring
5		127-193	Sparkplug, RC14YC	42	2	101-95	Bearing, Ball-1.25x72mm
6			See Section 4.0 Clutch System	43	1	24 418 05	Sensor, Oxygen
7	1	108-84	Washer, Engine Clutch	44	4	108-15	Washer, .42x.81x.05 Zn
8	1	112-160	HHCS, 7/16-20 x 5.0" Lg	45		112-156	Plug, Oil Drain 3/8-18 NPT Hex
9	1	127-137HD	Drive Belt - Avg/HDi Heavy Duty	46	1	24 089 46	Spring, Governer (Kohler #)
10			See Section 4.0 Clutch System	47	4	103-41	SHCS 3/8-16x1.25 Zn
11	1	110-03	Key 1/4 x 3/16 x 2.375 RC46	48	1	108-58	Washer, .47 x 1.37 x 12 Hi-Carbon
12	1	M-545016	Screw, Clamp Cable (Kohler #)	49	1	66 584 05	ECU (c/w engine)
13	1	112-164	HHCS 3/8-16 x 3.5 Gr5 Zn	50	1	112-102	Screw, Self Drill 12-14 x 3/4"
14	7	108-06	Lockwasher 3/8 Split Ring Zn	51	4	103-110	Set Screw, Cup, 5/16-24 x 1/2
15	1	108-46	Washer .40 x 1.37 x 1.2 Hi- Carbon	52	1	952-260	Bearing Flange, W/Trim
16	2	953-01	Mount, Service Brake Caliper	53	6	112-137	HHCS M10x1,25x20mm Zn
17	4	112-20	HHCS M8x1,25x25mm Zn	54	6	108-67	Lockwasher M10 Split- Ring Zn
18	1	953-09	Bracket, Speedo Mount	55	1	952-259	Bearing Flange, Grease W/Trim
19	2	165-22	Disc, Brake - Admiral	56	2	100-64	Tie Wrap - 5.5" - Black
20	2	112-203	SHCS 1/4-20x1/4 Zn	57	4	117-29	Locknut, Nylon 3/8-16 Zn
21	2	108-18	Washer .40 x 1.37 x .12 Zn	58	2	112-190	HHCS 1/2-13x3.00 Gr5 Zn
22	2	103-60	HHCS 3/8-24 x 1 Gr5 Zn	59	2	112-189	HHCS 1/2-13x1.25 Gr5 Zn
23	2	112-225	RHMS, 10-24 x 2.0 Zn	60	4	108-107	Lockwasher, 1/2", High Alloy
24	2	120-04	Washer .19x.50x.08 Zn	61	1	952-259	Bearing Flange, Grease W/Trim
25			See Section 9.0 Steering & Brake System	62	1	952-260	Bearing Flange, W/Trim
26	2	165-25	Disc, Brake, Service				
27	2	810-117	Coupler, Idler Shaft				
28	1	110-18	Key 1/4 x 1/4 x 1.75				
29	2	810-119	Shaft, Output, #60-10T				
30	1	12 237 01	Clamp, Cable (Kohler #)				
31	1	24 089 51	Spring, Throttle (Kohler #)				
32			See Section 9.0 Steering & Brake System				
33			See Section 9.0 Steering & Brake System				
34	10	112-201	Bolt, Shoulder M10 x 45				
35	2	117-10	Locknut, 10-24 N/I Zn				
36	18	117-77	Locknut, Nylon - M8 x 1,25mm Zn8				

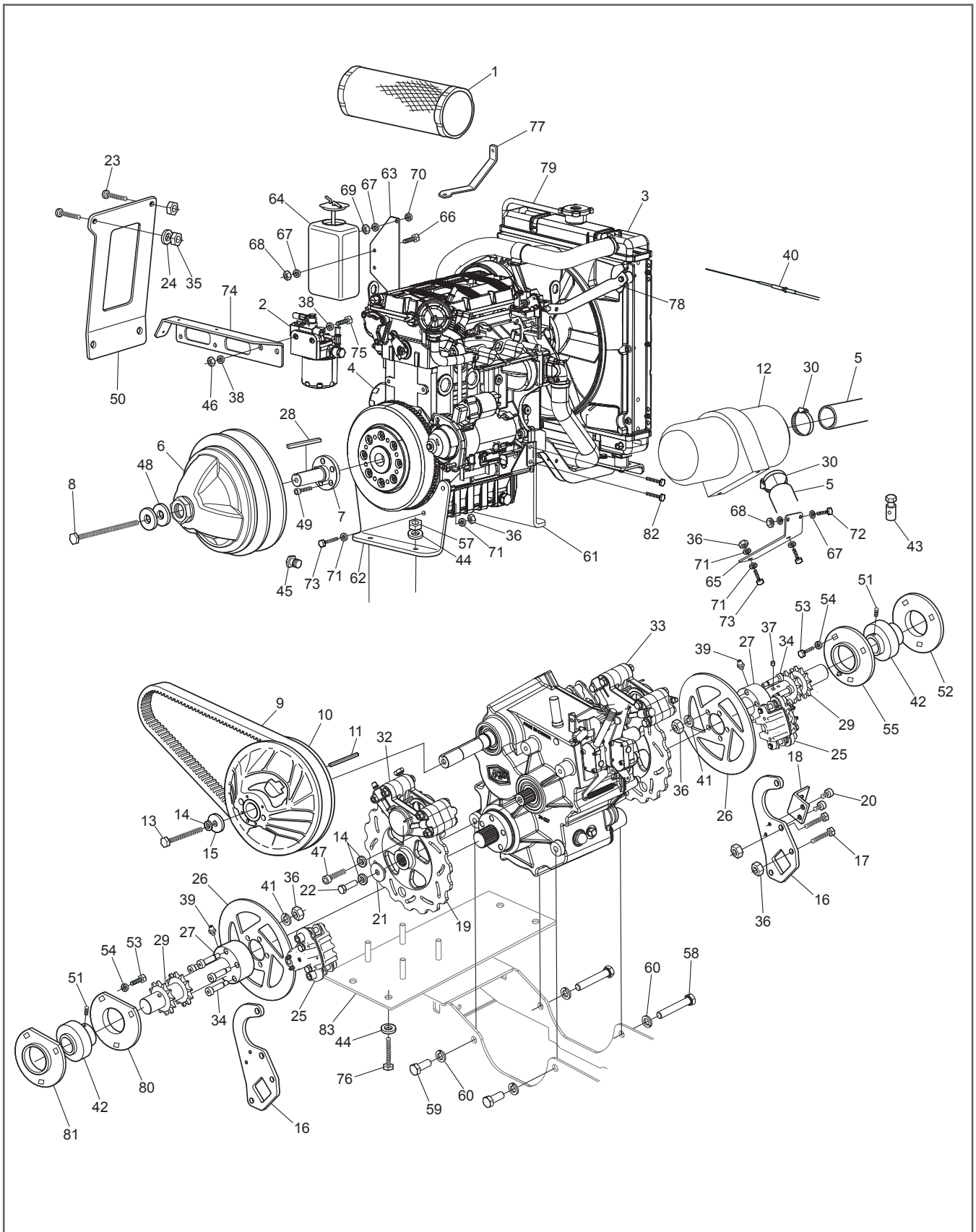

Ref.	Qty.	Part #	Description	Ref.	Qty.	Part #	Description
1	1	ED0021751240-S	Filter, Air	46	2	117-60	Locknut, Nyloc M10x1.5mm Zn
2	1	ED0021752880-S	Filter, Fuel	47	4	103-41	SHCS 3/8-16x1.25 Zn
3	1	KDW1003-5025A	Kohler 24HP Engine, Diesel	48	2	108-58	Washer, .47 x 1.37 x 12 Hi-Carbon
4	1	ED0021752850-S	Filter, Oil	49	5	112-179	SHCS M10x1,25x40
5	2	848-194	Hose, Intake Flex 2"Dia x 24"	50	1	952-168	Bracket, ECM XT
6			See Section 4.0 Clutch System	51	4	103-110	Set Screw, Cup, 5/16-24 x 1/2
7	1	953-67	Shaft, PTO - XTD	52	2	952-260	Bearing Flange, W/Trim
8	1	112-160	HHCS, 7/16-20 x 5.0" Lg	53	6	112-137	HHCS M10x1,25x20mm Zn
9	1	127-159HD	Drive Belt - Frontier Heavy Duty	54	6	108-67	Lockwasher M10 Split- Ring Zn
10			See Section 4.0 Clutch System	55	2	952-259	Bearing Flange, Grease W/Trim
11	1	110-03	Key 1/4 x 3/16 x 2.375 RC46	56	4	100-64	Tie Wrap - 5.5" - Black
12	1	ED0037004560-S	Air Cleaner	57	4	117-66	Locknut, Nylon 1/2-13Zn
13	1	112-164	HHCS 3/8-16 x 3.5 Gr5 Zn	58	2	112-190	HHCS 1/2-13x3.00 Gr5 Zn
14	7	108-06	Lockwasher 3/8 Split Ring Zn	59	2	112-189	HHCS 1/2-13x1.25 Gr5 Zn
15	1	108-46	Washer .40 x 1.37 x 1.2 Hi- Carbon	60	4	108-107	Lockwasher, 1/2", High Alloy
16	2	953-01	Mount, Service Brake Caliper	61	1	953-68	Support, Engine RH-XTD
17	4	112-20	HHCS M8x1,25x25mm Zn	62	1	953-69	Support, Engine LH-XTD
18	1	953-09	Bracket, Speedo Mount	63	1	953-81	Mount, Overflow Bottle-XTD
19	2	165-22	Disc, Brake - Admiral	64	1	825462	Overflow Tank Kit Mount, Air Filter - XTD HHCS
20	2	112-203	SHCS 1/4-20x1/4 Zn	65	1	953-77	M6x1,0x15mm
21	2	108-18	Washer .40 x 1.37 x .12 Zn	66	3	112-118	Washer .28x.62x.07 Zn
22	2	103-60	HHCS 3/8-24 x 1 Gr5 Zn	67	5	108-08	Locknut, Nylon M6x1 Zn
23	2	112-225	RHMS, 10-24 x 2.0 Zn	68	4	112-115	Nut, Hex M6x1,0 Zn
24	2	120-04	Washer .19x.50x.08 Zn	69	1	117-63	Lockwasher 1/4 Split Ring Zn
25			See Section 9.0 Steering & Brake System	70	1	108-03	Washer .34x.70x.06 Zn
26	2	165-25	Disc, Brake, Service	71	4	108-24	HHCS M6 x 1 x 40mm Zn
27	2	810-117	Coupler, Idler Shaft	72	2	112-98	HHCS M8x1,25x30mm Gr8.8 Zn
28	1	110-18	Key 1/4 x 1/4 x 1.75	73	6	112-233	Mount, Fuel Filter - XTD
29	2	810-119	Shaft, Output, #60-10T	74	1	953-75	HHCS M10x1,5x35mmZn
30	3	100-128	Clamp, Gear 2.25"	75	2	112-133	HHCS 1/2-13x1.75 Gr5 Zn
31	1	ED0021000890-S	Glow Plug	76	4	112-237	Rad Support, Fwd - XTD
32			See Section 9.0 Steering & Brake System	77	1	953-90	Rad Support, Rear - XTD
33			See Section 9.0 Steering & Brake System	78	1	953-91	Tubing, 1/4"ID - 10" Long
34	10	112-201	Bolt, Shoulder M10 x 45	79	1	127-160-10	Bearing Flange, Grease W/Trim
35	2	117-10	Locknut, 10-24 N/I Zn	80	1	952-259	Bearing Flange, W/Trim
36	18	117-77	Locknut, Nylon - M8x 1,25mm Zn	81	1	952-260	HHCS M12x1,75x35mm 8.8 Zn
37	1	613-127	Magnet, Speedometer	82	2	112-248	Mount, Engine - XTD
38	4	108-15	Washer .42x.81x.05 Zn	83	1	950-36	
39	2	100-127	Fitting, Grease STR 1/4-28 TPR				
40	1	612-136	Cable Asm., Throttle, XTD				
41	11	108-05	Lockwasher 5/16 Split-Ring				
42	2	101-95	Bearing, Ball-1.25x72mm				
43	1	ED0058301190-S	Clamp, Cable				
44	8	108-103	Washer, 0.51x0.94x0.10 Zn				
45		112-156	Plug, Oil Drain 3/8-18 NPT Hex				

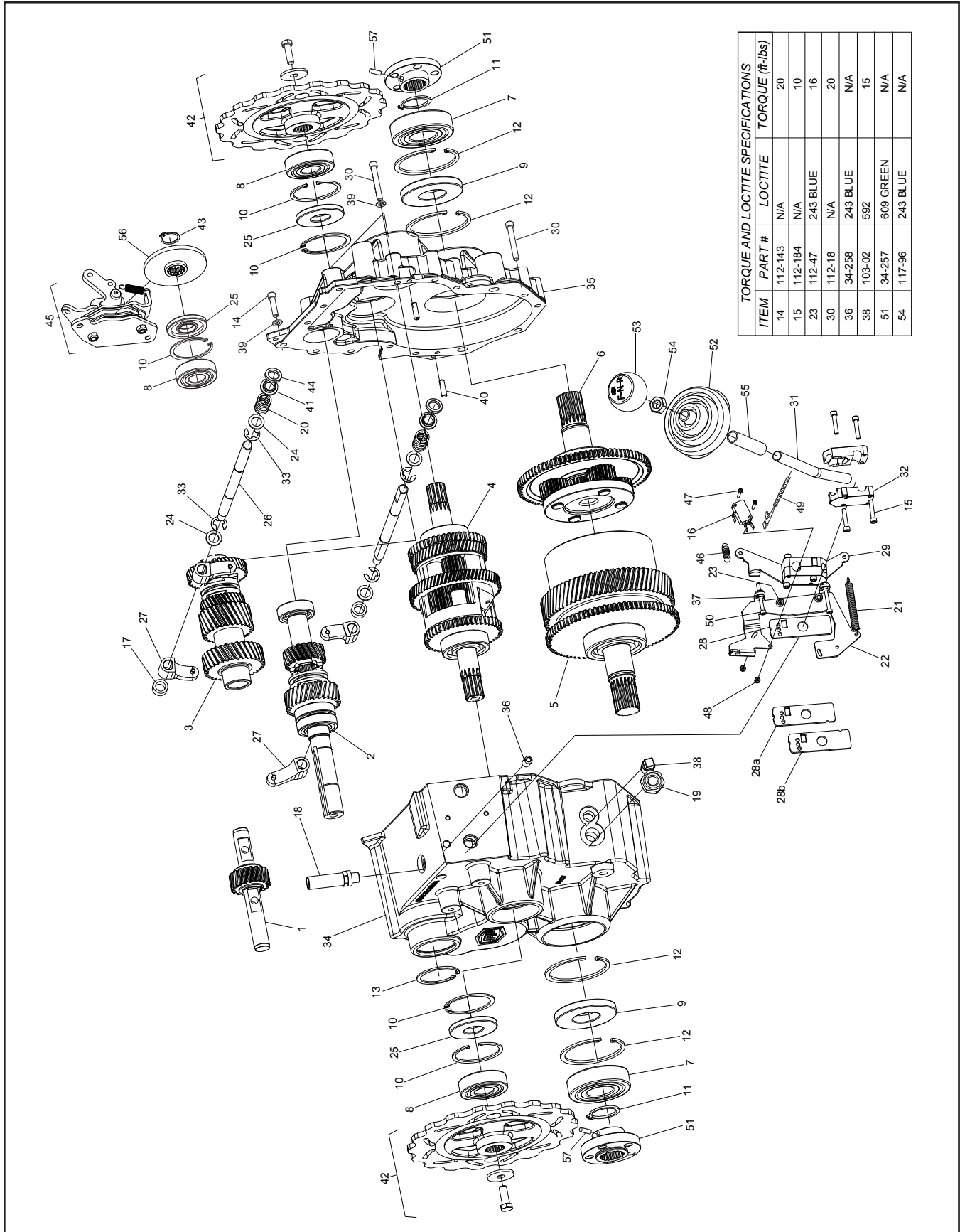

Ref.	Qty.	Part #	Description	Ref.	Qty.	Part #	Description
1-6	1	34-200-7.1 -FG	Transmission Admiral 7.1 Ratio See Section 8.1 Trans. Sub Assemblies	49	1	613-112	Wire Harness, Neutral Start
7	2	101-81	Bearing, Ball 6307 ZZE	50	2	112-195	SHCS 8-32 x 1.5 Stainless
8	3	101-86	Bearing, Ball 6305 Zz	51	2	34-262	Coupler, Output Shaft, Pinned
9	2	102-33	Seal, Oil 35x80x10	52	1	609-44	Boot, F-N-R Shifter
10	5	106-05	Retaining Ring HO-244-PA	53	1	127-226	Knob, Shift F-N-R - HD
11	2	106-23	Retaining Ring SH-0137-PA	54	1	117-96	Nut, Jam 1/2-13
12	4	106-24	Retaining Ring H0-312-PA	55	1	127-229	Sleeve, Insulating - 1.25"
13	1	106-26	Retaining Ring H0-206-PA	56	1	165-52	Rotor, E-Brake
14	10	112-143	SHCS 5/16 x 1.25 Zn	57	2	104-75	Pin, Spring, 3/16x13/16 Zn
15	8	112-184	SHCS, 10-32 x 1				
16	1	613-151	Switch, Micro, Roller Lever				
17	2	114-21	Spacer, .51x.75x.36				
18	1	34-245	Plug, Fill/Vent 1/2 BSPP				
19	1	34-251	Site Glass, 1/2 BSP Aluminum				
20	2	127-186	Spring, Comp. 0.70x1.28				
21	1	127-194	Spring, Ext .360x3.0				
22	1	34-241	Bracket, Switch, Spring Mount				
23	2	112-47	SHCS 1/4-20 x 1.0 Zn				
24	3	108-35	Washer .53x1.06x.09 Zn				
25	3	102-37	Seal, Oil 25x62x7				
26	2	34-231	Shaft, Shift - F-N-R				
27	4	34-232	Fork, Shift - Half				
28	1	34-233	Plate, Detent				
28a	1	34-233L	Plate, Detent, Left Adj.				
28b	1	34-233R	Plate, Detent, Right Adj.				
29	1	34-242	Bracket, Spring Mount				
30	8	112-18	SHCS 5/16x2.25				
31	1	34-259	Lever, XTI, F-N-R				
32	4	34-236	Clamp, Lever Shaft				
33	3	106-30	Retaining Ring E-0050 E				
34	1	34-227	Housing, Admiral, Left (includes Ref. # 36)				
35	1	34-228	Housing, Admiral, Right				
36	1	34-258	Plunger, Ball - Nose Spring				
37	4	117-92	Nut, Hex Machine #8-32 Zn				
38	1	103-02	Plug, Magnetic 3/8-18Npt Sq. Hd				
39	11	108-05	Lockwasher 5/16 Split-Ring				
40	2	104-03	Pin, Dowel 1/4x7/8				
41	2	105-33	Bushing, Flange				
42			See Section 7.0 Power Pack				
43	1	106-29	Retaining Ring SH-0093-PA				
44	2	102-36	Seal, Shift Shaft - 0.5 x .75 x .125				
45			See Section 10.0 Parking Brake				
46	1	127-195	Spring, Ext., .75 x 2.73				
47	2	112-172	SHCS 5-40 x 3/4 Zn				
48	2	112-173	Locknut, #5-40 Zn				

8.1 Transmission Sub-Assemblies

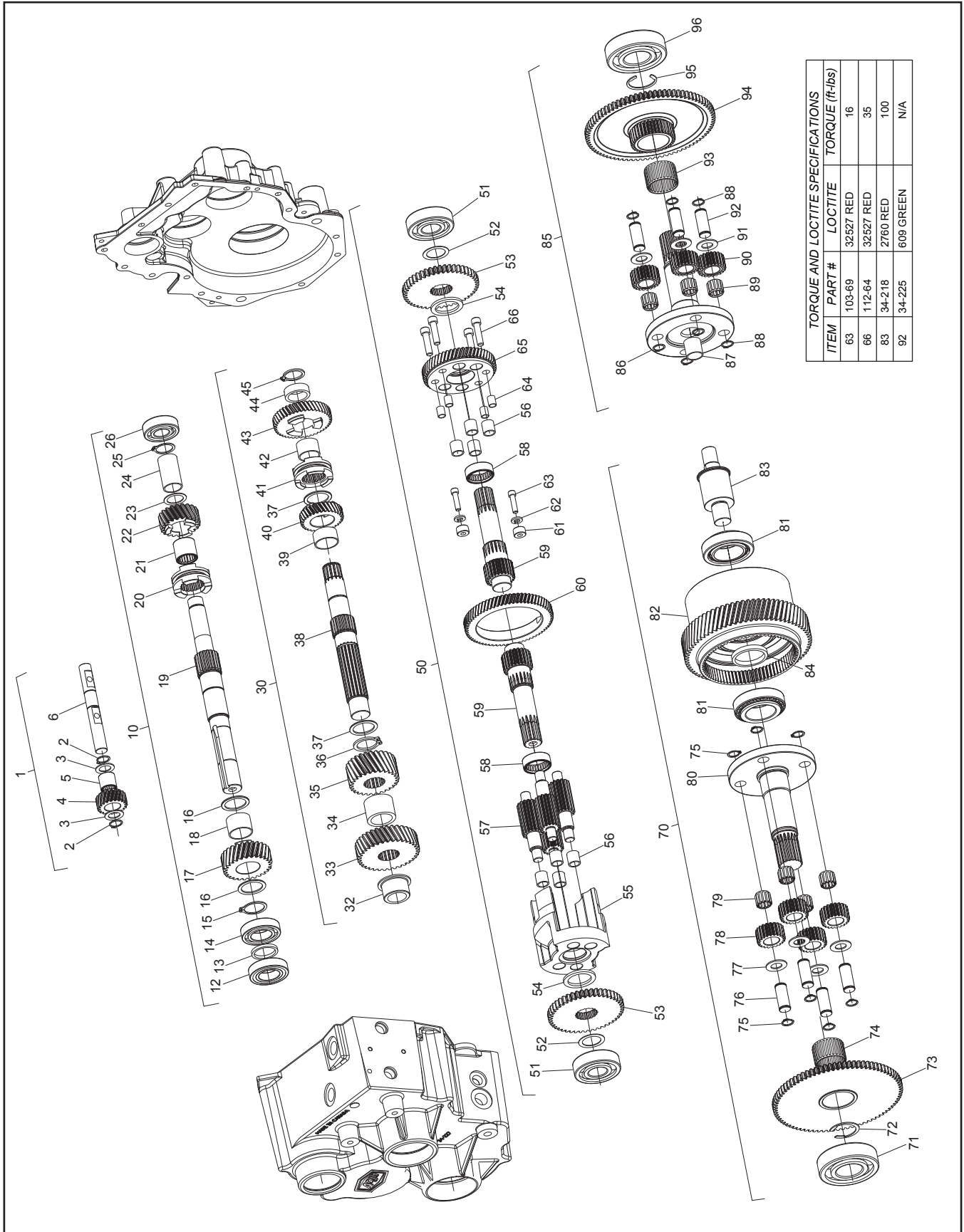

Ref.	Qty.	Part #	Description	Ref.	Qty.	Part #	Description
1	1	34-290	Asm, Reverse Shaft - Adm. includes:	60	1	34-205	Gear, Helical - 67T
2	2	106-25	Retaining Ring SH-0078-PA	61	2	105-28	Bushing, Dowel .26x.625x.36
3	2	108-99	Washer, Thrust .79x1.25 x .06	62	2	108-03	Lockwasher 1/4 Split Ring Zn
4	1	34-220	Pinion, Idler - 20T	63	2	103-69	SHCS, 1/4-20 x 1.5 Zn
5	1	101-87	Bearing, Needle HMK20x27x25	64	4	105-23	Bushing, Dowel - .312 x .5
6	1	34-221	Shaft, Shift - Reverse	65	1	34-204	Gear, Helical - 55T
10	1	34-291-7.3	Asm, Input Shaft includes:	66	4	112-64	SHCS 5/16 x 18 x 1.25
12	1	101-89	Bearing, Ball 60/28 Llu	70	1	34-294-HS	Asm, Output Shaft LH-Adm. includes
13	1	114-19	Spacer, 1.12x1.375x.148	71	1	101-73	Bearing, Ball 6307 CL.N.
14	1	101-88	Bearing, Ball 60/28	72	1	106-31	Retaining Ring C-0137
15	1	106-27	Retaining Ring SH-112-PA	73	1	34-207-HS	Gear, Sun - 84T, 35T
16	2	108-98	Washer, Thrust 1.13x1.46x.062	74	1	101-83	Bearing, Needle KJ37x42x27S
17	1	34-215	Pinion, For.-27T,12Dp-7.3 Ratio	75	8	106-22	Retaining Ring SH-0056-PA
18	1	105-32	Bushing, Bronze 1.125x1.25x.875	76	4	34-225	Pin, Planet Carrier
19	1	34-213	Shaft, Input	77	4	108-93	Washer, .59x1.10x.06
20	1	34-224	Collar, Shift, For-Rev	78	4	34-217	Gear, Planet - 21T
21	1	101-90	Bearing, Needle HK2220	79	4	101-82	Bearing, Needle KM J15x21x17S
22	1	34-214	Pinion, Reverse - 21T,12Dp	80	1	34-263	Carrier Shaft, Grooved LH
23	1	114-17	Washer, Thrust .866x1.181x.039	81	2	101-76	Bearing, Tapered Roller 32008X
24	1	114-18	Spacer, .865x1.0x1.75	82	1	34-219	Planetary Hub
25	1	106-25	Retaining Ring SH-0078-PA	83	1	34-218	Shaft, Planetary Stub
26	1	101-01	Bearing, Ball 6204Z-C3	84	1	114-22	Spacer, 1.585x1.75x.245
30	1	34-295-7.3	Asm, Idler Shaft includes:	85	1	34-293-HS	Asm, Output Shaft RH - Adm. includes:
32	1	105-30	Bushing, Flanged 1x1.375	86	1	34-264	Carrier Shaft, Grooved RH
33	1	34-211	Gear, Helical - 35T- 7.3 Ratio	87	1	105-26	Bushing, Oilite .75x.875x.875
34	1	108-96	Spacer, 1.125x1.5x1.083	88	8	106-22	Retaining Ring SH-0056-PA
35	1	34-209	Pinion, Helical - 27T	89	4	101-82	Bearing, Needle KM J15x21x17S
36	1	106-28	Retaining Ring SHR-0112-PA	90	4	34-217	Gear, Planet - 21T
37	2	108-98	Washer, Thrust 1.13x1.46x.062	91	4	108-93	Washer, .59x1.10x.06
38	1	34-208	Shaft, Idler	92	4	34-225	Pin, Planet Carrier
39	1	105-31	Bushing, Bronze 1.125x1.25x.625	93	1	101-83	Bearing, Needle KJ37x42x27S
40	1	34-210	Pinion, Helical - 31T	94	1	34-207-HS	Gear, Sun - 84T, 35T
41	1	34-223	Collar, Shift, Hi-Low	95	1	106-31	Retaining Ring C-0137
42	1	105-29	Bushing, Oilite 1.0x1.125x.75	96	1	101-73	Bearing, Ball 6307 CL.N.
43	1	34-212	Pinion, Helical - 45T				
44	1	108-97	Spacer, 1.01x1.3x.409				
45	1	107-15	Retaining Ring SHR-98-PA				
50	1	34-292-HS	Asm, Differential - Adm. includes:				
51	2	101-40	Bearing, Ball 6305 Open				
52	2	114-16	Washer, SHIM .99x1.375x.030				
53	2	34-203-HS	Pinion, Spur - 43T				
54	2	108-94	Washer, Thrust 1.25x1.688x.125				
55	1	34-206	Cage, Differential				
56	8	105-27	Bushing, Oilite .5x.625x.625				
57	4	34-202	Gear, Planet - 15T				
58	2	101-84	Bearing, Needle HK3012				
59	2	34-201	Shaft, Brake				

9.0 Steering & Brake System

Conquest Parts Manual

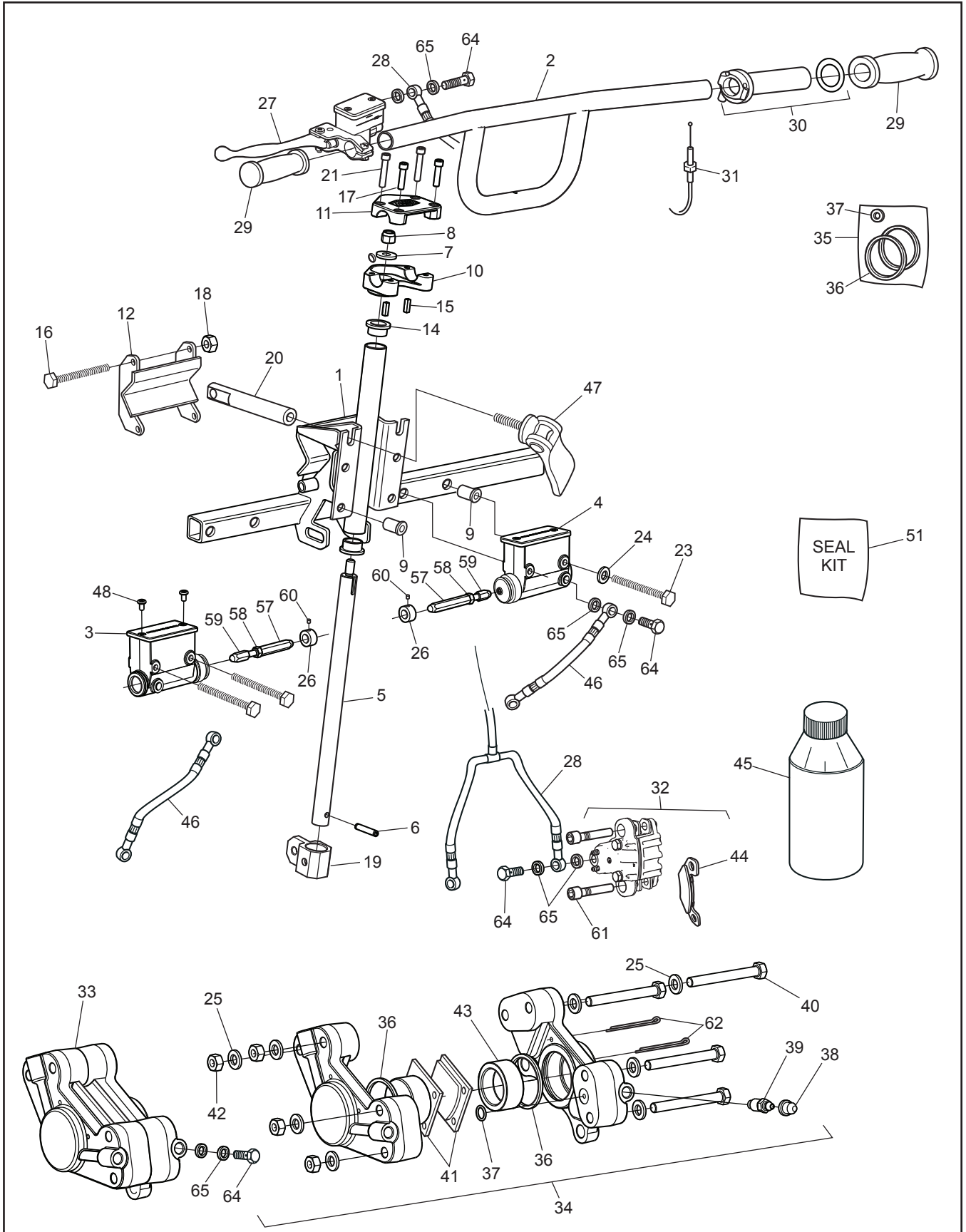

Conquest Parts Manual

9.0 Steering & Brake System

Ref.	Qty.	Part #	Description	Ref.	Qty.	Part #	Description
1	1	950-50	Steering Wldt. - XT	45		126-19	Fluid, Brake-Silicon Dot 5 - .35L
2	1	612-107	Handlebar Assembly	46	2	163-07	Hose Asm, Steering - XT
3	1	165-58	Master Cylinder, RH Wilwood	47	1	953-03	Handle, Quick Cam
4	1	165-57	Master Cylinder, LH Wilwood	48	2x2	160-42	Screw, FHMS M5 x 0,8 x 6mm
5	1	953-10	Shaft, Steering - XTI	51	1	165-37	Piston Seal Kit - Wilwood
6	1	104-42	Pin, Spring 1/4 x 1.5"	57	2	953-02	Pin, Female, Steering
7	2	108-47	Washer, .39 x .94 x .13 Zn Di-chr	58	2	117-03	Nut, Fin Hex 1/4-20 Zn
8	2	117-29	Locknut, Nylon 3/8-16 Zn	59	2	812-31	Pin, Male
9	8	117-79	Insert, M6 x 1,0 -10 mm OD	60	2	112-02	SHSS 10-24x1/4 Knurl Cup PT, PL
10	1	612-106	Clamp, Lower Handlebar	61	4	165-38	Caliper Pin, Service Brake HDi
11	1	612-105	Clamp, Upper Handlebar	62	2x2	168-07	Pin, Cotter 1/8 x 3.00 Zn
12	1	950-11	Wldt, Steering Bracket	63	2x1	161-25	O-Ring Kit - Master Cylinder (incl. Ref. 53, 55 & 56)
14	2	105-16	Bushing, Oilite - 3/4 x 1/2	64	7	160-44	Bolt, Banjo - M10 x 1,0 x 21,0
15	2	110-17	Key, 3/16 x 3/16 x .625	65	14	160-01	Washer, Copper - 1,5 x 10,0 x 14,0
16	2	103-111	HHCS 1/4-20 x 3.5 Zn	66	1	120-13	Rivet, 3/16 x 3/4 Black
17	2	112-47	SHCS, 1/4-20 x 1.0 Zn				
18	2	117-27	Locknut, Nylon 1/4-20 Zn				
19	1	953-06	Actuator, Steering				
20	1	953-07	Nut, Toggle				
21	2	103-69	SHCS 1/4-20 x 1.5 Zn				
22	1	126-93	Clamp, Nylon Wire - 1/2" ID				
23	4	112-114	HHCS M6 x 1 x 60mm Zn				
24	4	108-68	Lockwasher, Hi-Collar M6 Zn				
25	2x8	108-24	Washer, .34 x .70 x .06 Zn				
26	2	812-17	Collar				
27	1	165-31	Handbrake, Left Hydraulic				
28	1	163-08	Hose, Service Brake, XT				
29	2	127-35	Grip, Molded				
30	1	127-81	Throttle Twist Grip				
31	1	612-135	Cable Asm., Throttle, XTI				
		612-136	Cable Asm., Throttle, XTD				
32	2	165-32	Caliper, Service (includes Ref. 44 & 61)				
33	1	166-10	Caliper, Hydraulic Brake - L w/o pads				
34	1	166-11	Caliper, Hydraulic Brake - R w/o pads				
35	2	161-05	O-ring Kit, Knott Caliper				
36	4		Seal, Piston				
37	2		Seal, Rubber				
38	2x1	168-20	Plug, Rubber				
39	2x1	168-02	Screw, Bleeding, Knott Caliper				
40	2x4	103-55	HHCS, 5/16-18 x 2.75 Gr Zn				
41	1	170-03	Pad Set (4), Brake - Non-Asbestos				
42	2x4	117-03	Nut, Fin Hex 5/16-18 Zn				
43	2x2	168-01	Piston, Knott Caliper				
44	1	165-36	Brake Pad (4) Replacement - Kit				

10.0 Parking Brake

Conquest Parts Manual

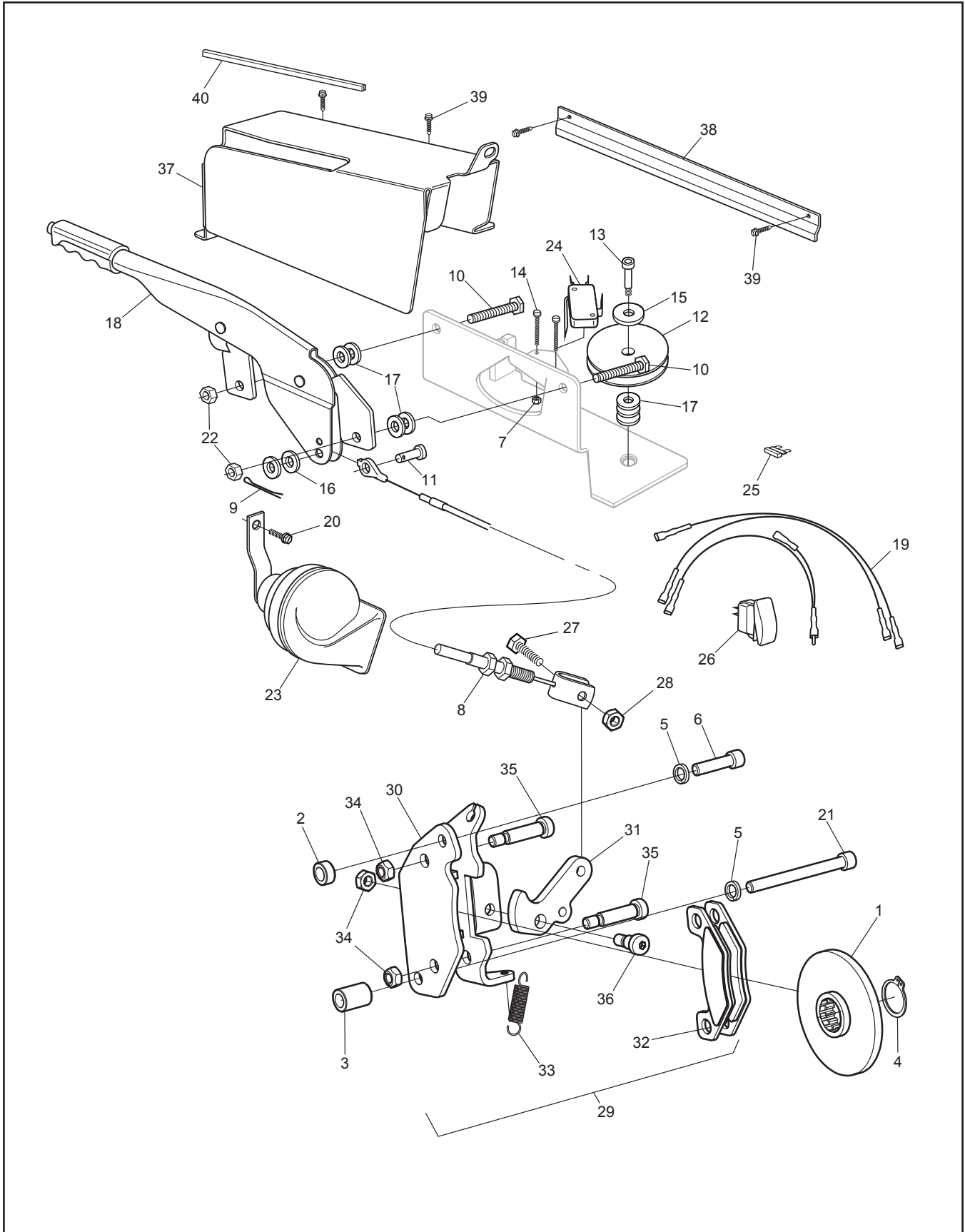

Ref.	Qty.	Part #	Description
1	1	165-52	Rotor, E-Brake
2	1	165-49	Spacer, ID.39 x OD.63 x .295
3	1	165-48	Spacer, ID.39 x OD.63 x .90
4	1	106-29	Retaining Ring SH-0093-PA
5	2	108-05	Lockwasher 5/16 Split-Ring
6	1	112-143	SHCS 5/16 x 1.25 Zn
7	2	112-173	Locknut, #5-40, Zn
8	1	850-81	Cable, Parking Brake
9	1	100-100	Pin, Cotter 1/8x3/4 Zn
10	2	103-06	HHCS 5/16-18x1.0 Gr5 Zn
11	1	104-27	Pin, Clevis 5/16x.75" Zn
12	1	850-79	Pulley, Parking Brake Cable
13	1	112-178	Bolt, Shoulder, 1/2 x 5/8
14	2	112-172	SHCS 5-40 x 3/4 Zn
15	1	108-35	Washer .53 x 1.06 x .09 Zn
16	2	108-24	Washer .34x.70x.06 Zn
17	7	108-47	Washer .39x.94x.13 Zn Di-Chro
18	1	809-147	Lever, Parking Brake
19	1	848-176	Harness, Horn Momentary*
20	1	112-19	Screw,IHWH T/C Slot 1/4-20x1/2*
21	1	112-228	SHCS 5/16-18 x 3.25 Zn
22	2	117-21	Locknut, Nylon 5/16-18 Zn
23	1	848-87	Horn, Electric*
24	1	613-120	Switch, Micro, Lever
25	1	118-52	Fuse, 10A 2-Prong (AT010)*
26	1	848-175	Switch, Horn Momentary*
27	1	103-08	HHCS 1/4-20 x 1.0 Zn
28	1	117-27	Locknut, Nylon 1/4-20 Zn
29	1	165-50	Caliper, Parking Brake, Ass'y(incl. Ref. #'s 30-36)
30	1	165-44	Caliper, Wldt Parking Brake
31	1	165-51	Cam, Caliper, Park Brake
32	1	165-36	Brake Pad Replacement Kit
33	1	127-280	Spring, Extension 3/8" x 1.75"
34	3	117-25	Nut, Conelock 5/16-18
35	2	112-224	Bolt, Shoulder 3/8 x 1.25
36	1	112-223	Bolt, Shoulder 3/8 x 0.38
37	1	952-85	Guard, P-Brake - XT
38	1	953-42	Cover, Brake Cable, XT
39	4	112-102	Screw, Self Drill 12-14 x 3/4"
40	14"	953-96RM	Trim, Neoprene W/Glue

*If equipped

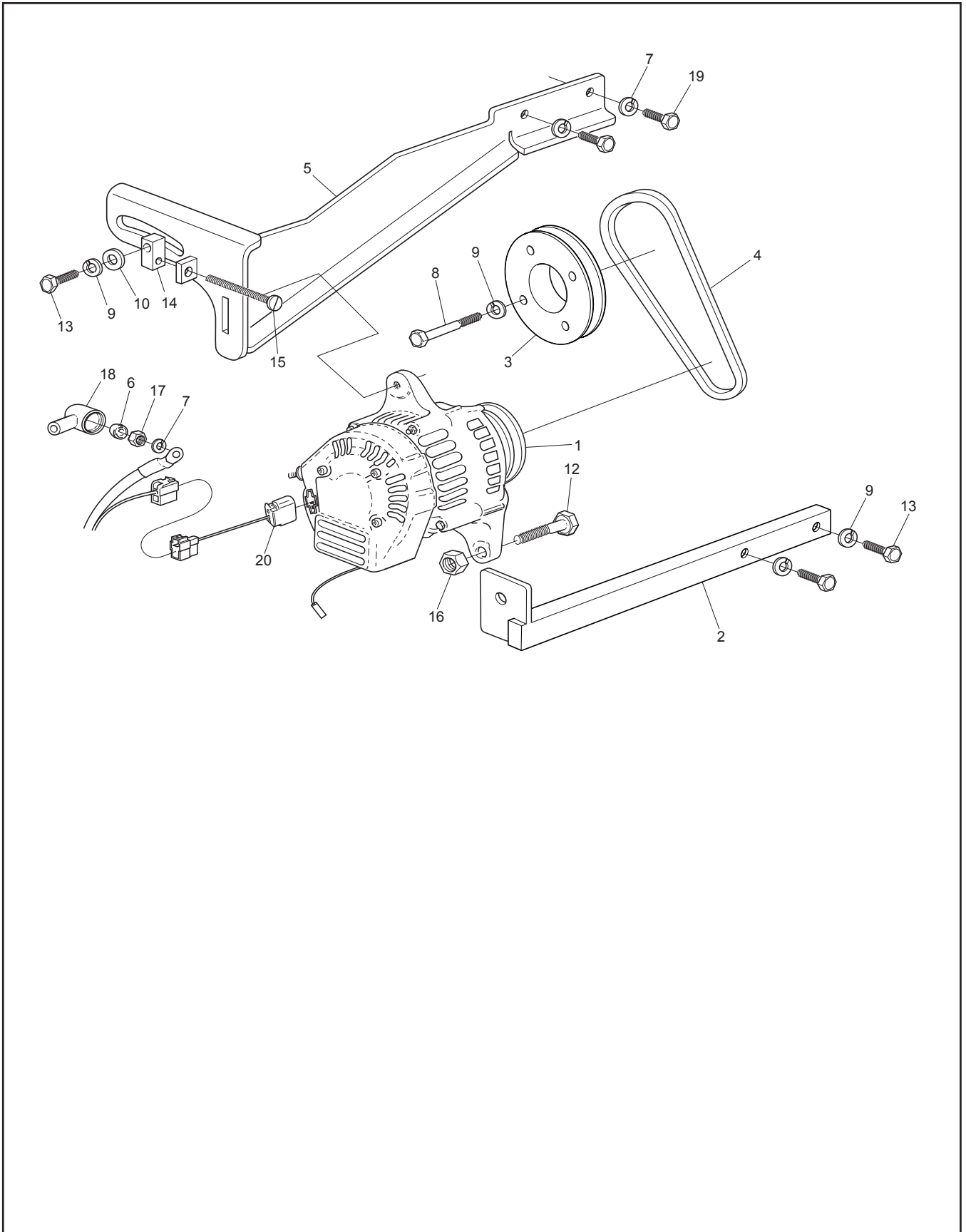

Ref.	Qty.	Part #	Description
1	1	958-167	Acc., Alternator Ass'y 60A XTl
2	1	850-191	Bracket Assy, Altr Engine Lower
3	1	850-59	Pulley, V-Belt
4	1	850-45	V-Belt, 3/8" x 19"
5	1	850-234	Bracket Ass'y, Altr. Upper 60A XTl
6	1	117-94	Pushnut, 5/32" Shaft
7	3	108-03	Lockwasher 1/4" Split Ring Zn
8	4	112-167	HHCS M8 x 1,25 x 80 mm Zn
9	7	108-05	Lockwasher 5/16" Split Ring
10	1	108-24	Flat Washer .34 x .70 x .06 Zn
12	1	112-22	HHCS M10 x 1,50 x 50mm Zn
13	3	112-63	HHCS M8 x 1.25 x 35mm Gr5 Zn
14	1	850-52	Block, Adjuster
15	1	112-65	RHMS 1/4 - 20 x 3" Phil Zn
16	1	117-60	Locknut, Nyloc M10x1.5mm Zn8
17	1	117-63	Nut, Hex M6 x 1.0 Zn
18	1	613-45	Insulator, Terminal (6ga.)
19	2	112-97	HHCS M6 x 1,0 x 25mm Zn
20	1	613-222	Wire Harness, Alt 60A XTl

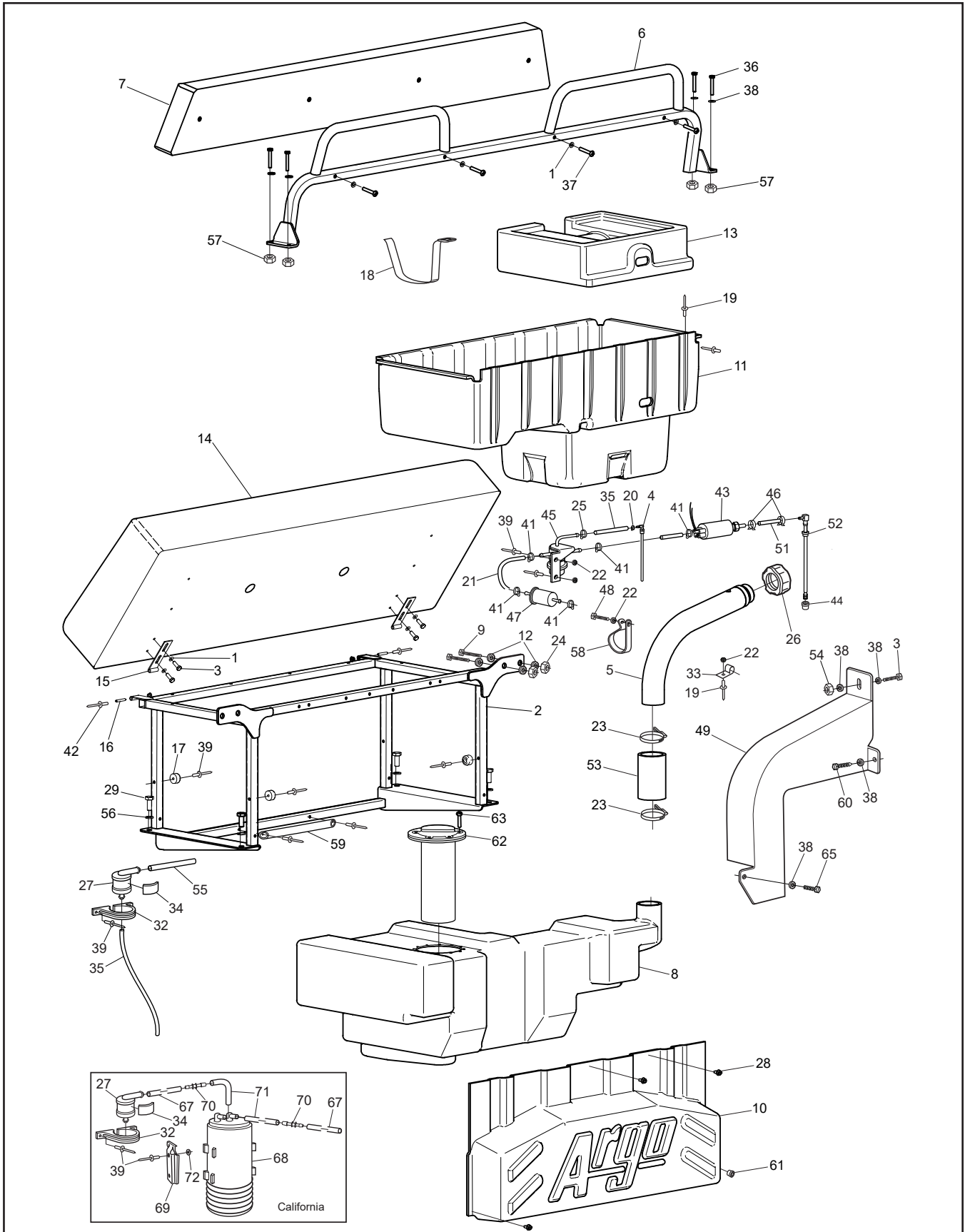

Conquest Parts Manual

12.0 Fuel System & Seat Assembly-XT

Ref.	Qty.	Part #	Description	Ref.	Qty.	Part #	Description
1	8	108-03	Lockwasher 1/4 Split Ring Zn	51	2"	608-69RM	Hose, Fuel - 5/16" ID Carb
2	1	950-13	Wldt, Bench Frame, XT	52	1	953-23	Pick-up, Fuel, XT
3	5	112-04	HHCS 1/4-20x3/4 Gr2 Zn	53	.5	125-94	Hose, Filler
4	1	608-138	Return, Fuel Port	54	1	117-27	Locknut, Nylon 1/4-20 Zn
5	1	950-31	Tube Ass'y, Fuel Fill - XT	55	1	126-101RM	Hose, Vent 3/16" ID
6	1	950-08	Frame, Backrest - Std (shown)	56	4	108-67	Lockwasher M10 Split-Ring Zn
or	1	958-337	Frame, Backrest - Deluxe	57	4	112-115	Locknut, Nylon M6 x 1 Zn
7	1	608-39CF	Backpad ASM, CF-Std (shown)	58	1	127-276	Clamp, Loop, 2-1/4"-XT
or	1	850-415	Seat, FRNT Backrest-Deluxe	59	1	952-146	Bumper, Fuel Tank - XT
8	1	951-18	Tank, Fuel Loperm - XT	60	1	112-102	Screw, Self Drill 12-14x3/4"
9	4	112-133	HHCS M10x1,5x35mmZn-8.8	61	1	117-79	Insert, M6x1,0 -10 mm OD
10	1	951-11	Cover, Fuel Comps - XT	62	1	953-39	Sender, Fuel - 5.5-15.5
11	1	951-09	Toolbox, XT - Bench Seat				(Prior to S.N. 34049)
12	8	108-15	Washer .42x.81x.05 Zn	1	1	953-53	Sender, Dip Tube (From
13	1	951-10	Cover, Battery -XT				S.N. 34049)
14	1	608-88CF	Seat ASM, Bench-Carb. Fiber	63	5	112-221	PHMS, Phil 10-32 x 5/8"
15	2	608-81	Hinge, Seat, Bolted				(Prior to S.N. 34049)
16	2	104-43	Pin, 3/16" x 1-1/8"	5	1	112-231	PHMS, M5 - 0.8 x 20 (From
17	3	126-102	Bumper, Recessed Hole				S.N. 34049)
18	1	608-56	Strap, Battery	64	1	953-40	Hardware, Fuel Sender
19	17	120-09	Rivet 3/16x1 - Black				(Prior to S.N. 34049) Not
20	4	112-79	Clamp, Hose, 1/2" - Red				shown
21	1	608-69	Hose, Fuel 5/16" ID x 7.5' - Carb	65	1	112-220	HHCS M6x1X20mm Gr Zn
22	10	120-04	Washer .19 x .50 x .08 Zn				United States Vehicle Kit
23	2	100-12	Clamp, Gear 2.25" HF-36	8	1	951-18	Tank, Fuel Loperm - XT
24	4	117-60	Locknut, Nyloc M10x1.5mm Zn	1	1	127-273	Plate, Serial Blank Double
25	1	112-253	Clamp, Fuel Injection 1/4"	1	1	127-274	Label, U.S EPA EVAP
26	1	126-100	Fuel Cap, Tethered				Approval
27	1	609-47	Valve, Rollover	66	2	120-24	Rivet, Alum - 3/32 x 3/8
28	4	112-19	Screw, IHWH T/C Slot 1/4-20x1/2				Black
29	4	112-93	HHCS M10 x 1,5 x 25mm				California Vehicle Kit
32	1	609-50	Clamp, Rollover Valve	8	1	608-120	Tank, Fuel Low Permeation
33	7	126-93	Clamp, Nylon Wire - 1/2" ID	1	1	127-273	Plate, Serial Blank Double
34	1	126-60	Vinyl Strip 1/2" x 1/4"	1	1	127-274	Label, U.S EPA EVAP
35	1.25'	127-160RM	Tubing, 1/4 ID Clear Plastic				Approval
36	4	112-98	HHCS M6 x 1 x 40mm Zn	39	2	120-13	Rivet - 3/16 x 3/4 Black
37	4	103-03	PHMS, Phil 1/4-20 x 1.50 Zn	66	4	120-24	Rivet, Alum - 3/32 x 3/8
38	8	108-08	Washer .28 x .62 x .07 Zn				Black
39	33	120-13	Rivet, 3/16 x 3/4 Black	1	1	127-275	Label, Carb EVAP Approval
41	5	112-243	Clamp, Fuel Injection 5/16"	67	1	126-101RM	Hose, Vent 3/16" ID
42	4	120-31	Rivet, 3/16" x 1/4, Open End	68	1	609-45	Carbon Canister 800cc
43	1	24 393 52	Fuel Pump, EFI	69	1	609-46	Bracket, Carbon Canister
44	1	608-136	Grommet, Fuel Return	70	2	609-48	Reducer, Barbed 1/4" to3/16"
45	1	24 403 16	Regulator, Fuel Pressure	71	2	127-160-3	Hose, 1/4IDx3/8OD - 3" Long
46	2	112-78	Clamp, Hose, 9/16	72	2	120-05	Washer .19x.50x.04 Zn
47	1	24 050 03	Filter, Fuel Line - EFI - c/w engine				
48	1	103-25	PHMS 10-24x3/4 Zn				
49	1	950-32	Cover, Fuel Fill, XT				

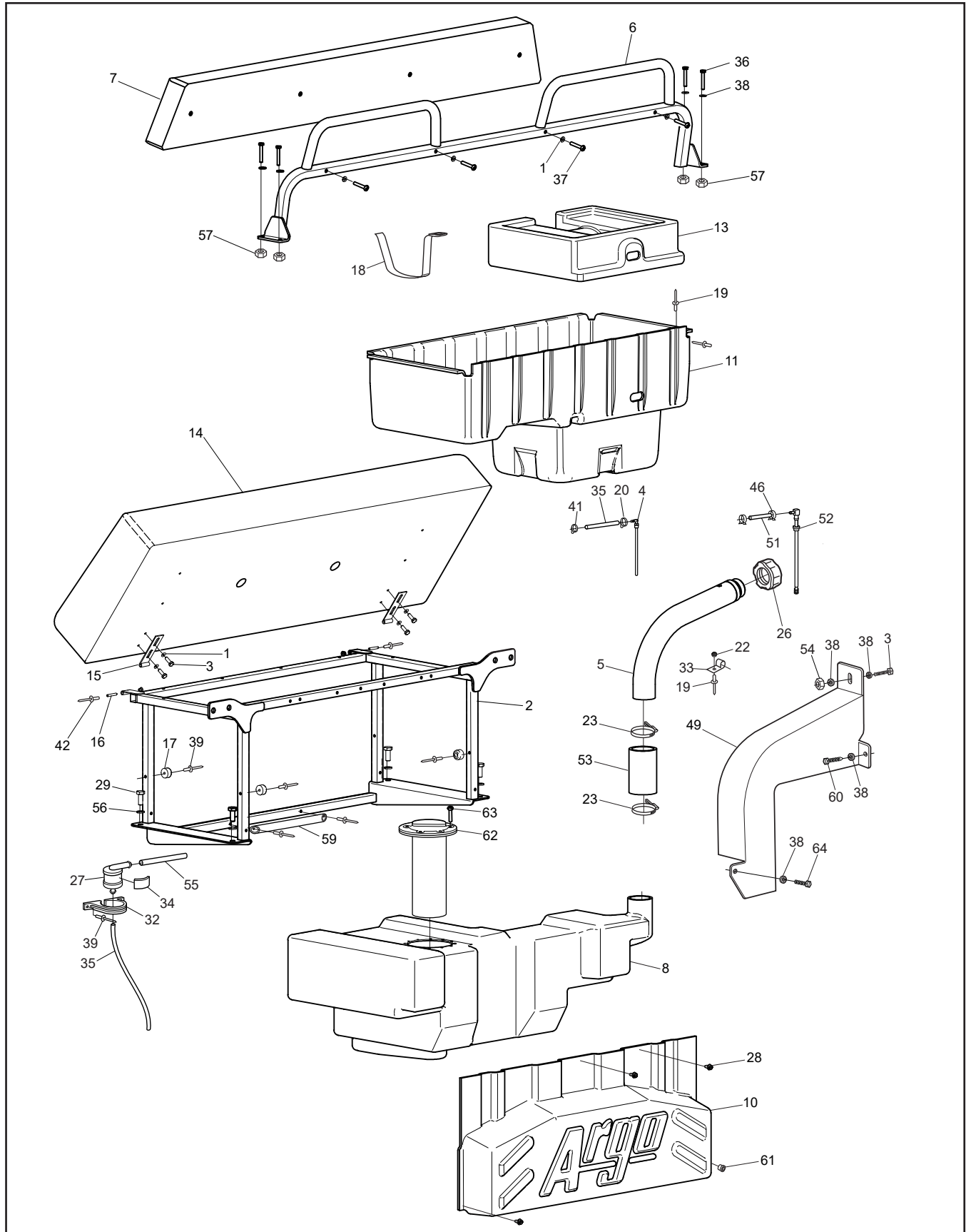

Ref.	Qty.	Part #	Description	Ref.	Qty.	Part #	Description
1	8	108-03	Lockwasher 1/4 Split Ring Zn	48	1	103-25	PHMS 10-24x3/4 Zn
2	1	950-13	Wldt, Bench Frame, XT	49	1	950-32	Cover, Fuel Fill, XT
3	5	112-04	HHCS 1/4-20x3/4 Gr2 Zn	50	1	808-133	Reducer, 5/16" to 1/4" Barbed
4	1	608-138	Return, Fuel Port	51	2"	608-69RM	Hose, Fuel - 5/16" ID Carb
5	1	950-31	Tube Ass'y, Fuel Fill - XT	52	1	953-23	Pick-up, Fuel, XT
6	1	950-08	Frame, Backrest - Std (shown)	53	.5	125-94	Hose, Filler
or	1	958-337	Frame, Backrest - Deluxe	54	1	117-27	Locknut, Nylon 1/4-20 Zn
7	1	608-39CF	Backpad ASM, CF-Std (shown)	55	1	608-146-4	Hose, Fuel-3/16"ID x 4"LG
or	1	850-415	Seat, FRNT Backrest-Deluxe	56	4	108-67	Lockwasher M10 Split-Ring Zn
8	1	951-18	Tank, Fuel Loperm - XT	57	4	112-115	Locknut, Nylon M6 x 1 Zn
9	2	103-77	HHCS, 1/4-28 x 2.0	58	1	609-48	Reducer, Barbed 1/4" to 3/16"
10	1	951-11	Cover, Fuel Comps - XT	59	1	952-146	Bumper, Fuel Tank - XT
11	1	951-09	Toolbox, XT - Bench Seat	60	1	112-102	Screw, Self Drill 12-14x3/4"
12	1		See Section 13.0 Electrical System	61	1	117-79	Insert, M6x1,0 -10 mm OD
13	1	951-10	Cover, Battery -XT	62	1	953-53	Sender, Dip Tube
14	1	608-88CF	Seat ASM, Bench-Carb. Fiber	63	5	112-231	PHMS, M5 - 0.8 x 20
15	2	608-81	Hinge, Seat, Bolted	64	1	112-220	HHCS M6x1X20mm Gr Zn
16	2	104-43	Pin, 3/16" x 1-1/8"				
17	3	126-102	Bumper, Recessed Hole				
18	1	608-56	Strap, Battery				
19	17	120-09	Rivet 3/16x1 - Black				
20	2	112-79	Clamp, Hose, 1/2" - Black				
21	1	608-69	Hose, Fuel 5/16" ID x 7.5' - Carb				
22	7	120-04	Washer .19 x .50 x .08 Zn				
23	2	100-12	Clamp, Gear 2.25" HF-36				
25	1	112-07	RHMS 10-24 x 1.50 Zn				
26	1	126-100	Fuel Cap, Tethered				
27	1	609-47	Valve, Rollover				
28	4	112-19	Screw, IHWH T/C Slot 1/4-20x1/2				
29	4	112-93	HHCS M10 x 1,5 x 25mm				
30	10	108-42	Washer .21 x 1.0x.06 Zn				
31	3	117-10	Locknut, Nylon #10-24 Zn				
32	1	609-50	Clamp, Rollover Valve				
33	7	126-93	Clamp, Nylon Wire - 1/2" ID				
34	1	126-60	Vinyl Strip 1/2" x 1/4"				
35	72"	127-160RM	Tubing, 1/4 ID Clear Plastic				
36	4	112-98	HHCS M6 x 1 x 40mm Zn				
37	4	103-03	PHMS, Phil 1/4-20 x 1.50 Zn				
38	8	108-08	Washer .28 x .62 x .07 Zn				
39	33	120-13	Rivet, 3/16 x 3/4 Black				
40	1	608-137	Plug, Push-In				
41	2	112-243	Clamp, Fuel Injection 5/16"				
42	4	120-31	Rivet, 3/16" x 1/4, Open End				
43	1	608-68-4	Hose, Fuel-1/4"ID x 4"LG				
44	1	608-136	Grommet, Fuel Return				
45	1	608-68	Hose, Fuel -1/4"ID, Bio-Diesel				
46	2	112-78	Clamp, Hose, 9/16				
47	1	608-69	Hose, Fuel-5/16" ID, Carb-10'				

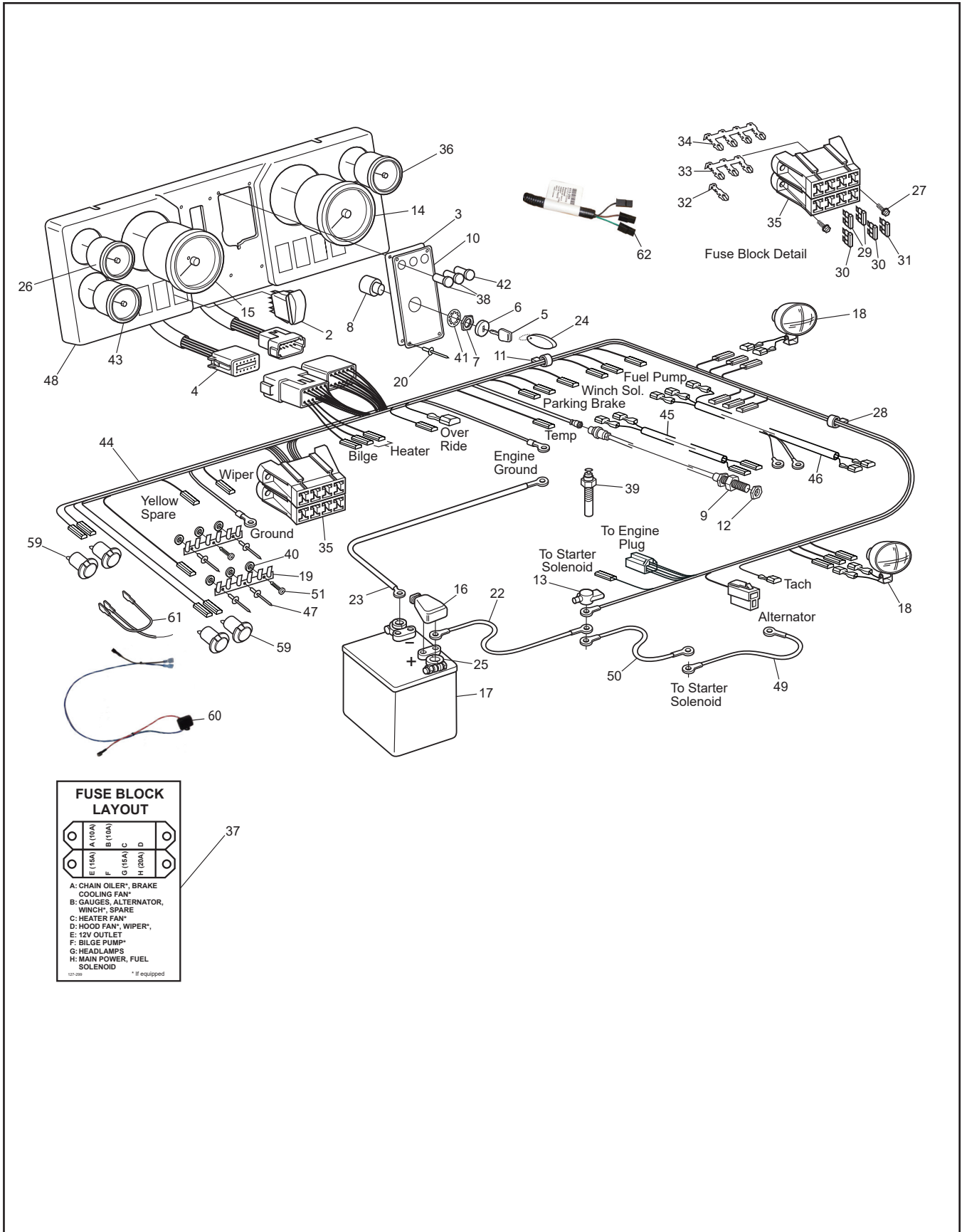

Conquest Parts Manual

13.0 Electrical System - XT

Ref.	Qty.	Part #	Description	Ref.	Qty.	Part #	Description
2	1	613-153	Switch, Light	50	1	613-183	Wire Harness, Power XT
3	1	127-234	Plate, Ignition - XT	51	1	112-102	Screw, Self Drill 12-14 x 3/4"
4	1	613-181	Wire Harness, Gauges XT	59	2	118-80	Outlet, 12 Volt & Twin USB
5	2	127-108	Key, Molded	60	1	613-231	Wire Harness, USB
6	1	127-107	Bezel - Cover, Nut	61	1	613-243	Harness, USB, XT
7	1	127-106	Nut, Flanged - Plastic	62	1	613-259	Harness, Winch Diode
8	1	127-105	Switch - Ignition				
9	1	613-126	Sensor, Speedo Pickup				
10	1	127-236	Label, Ignition-XT				
11	4	127-24	Clamp, Nylon - 1" ID				
12	1	117-87	Nut, M12 x 1.25, Zn				
13	1	613-124	Insulator, 2 Way w/cap, Red				
14	1	613-184	Gauge, Tachometer - XT				
15	1	613-185	Gauge, Speedometer 0-45K XT				
16	1	127-55	Cap, Battery Terminal - Red				
17	1	126-108	Battery, 12V, XT				
18	2	613-175	Headlight, 12V Bottom Mnt - XT				
	2	613-307	Headlight Bulb, 12V 65W				
19	2	613-37	Terminal Strip, Ground				
20	4	120-33	Rivet, 1/8 x 1/2 Black				
21	1	613-46	Insulator, Terminal (2 ga.)				
22	1	613-197	Wire, Positive Battery XT				
23	1	613-198	Wire, Negative Battery XT				
24	1	681-00	FOB, Key - Floating				
25	2	127-56	Terminal, Battery Post				
26	1	613-186	Gauge, Coolant Temp XT				
27	2	112-51	Screw, IHWH T/C #10-24 x 5/8				
28	4	126-93	Clamp, Nylon Wire - 1/2" ID				
29	2	118-52	Fuse, 10A 2 Prong (AT010)				
30	2	118-49	Fuse, 15A 2 Prong (AT015)				
31	1	118-53	Fuse, 20A 2 Prong (AT020)				
32	9	118-62	Terminal - Fuse, single				
33	1	118-63	Terminal - Fuse, triple				
34	1	118-61	Terminal - Fuse, quad				
35	2	118-60	Block - Fuse, 8 position (4 fuse)				
36	1	613-187	Gauge, Battery Voltage XT				
37	1	127-299	Label, Fuse Panel - XT				
38	2	613-191	Light, Indicator Red				
39	1	119-11	Sender, Coolant Temp, VDO				
40	6	120-04	Washer .19 x .50 x.08 Zn				
41	1	114-26	Lockwasher, 5/8 Int. Tooth				
42	1	613-192	Light, Indicator Amber				
43	1	613-199	Gauge, Fuel Level XT				
44	1	613-176	Wire Harness, Kohler EFI XT				
45	1	613-177	Wire Harness, Park Brake XT				
46	1	613-178	Wire Harness, Fuel Pump XT				
47	2	120-15	Rivet - 1/8 x 7/16				
48	1	613-180	Dash Asm, Panel Gauge Wire XT				
49	1	613-182	Wire Harness, Alternator XT				

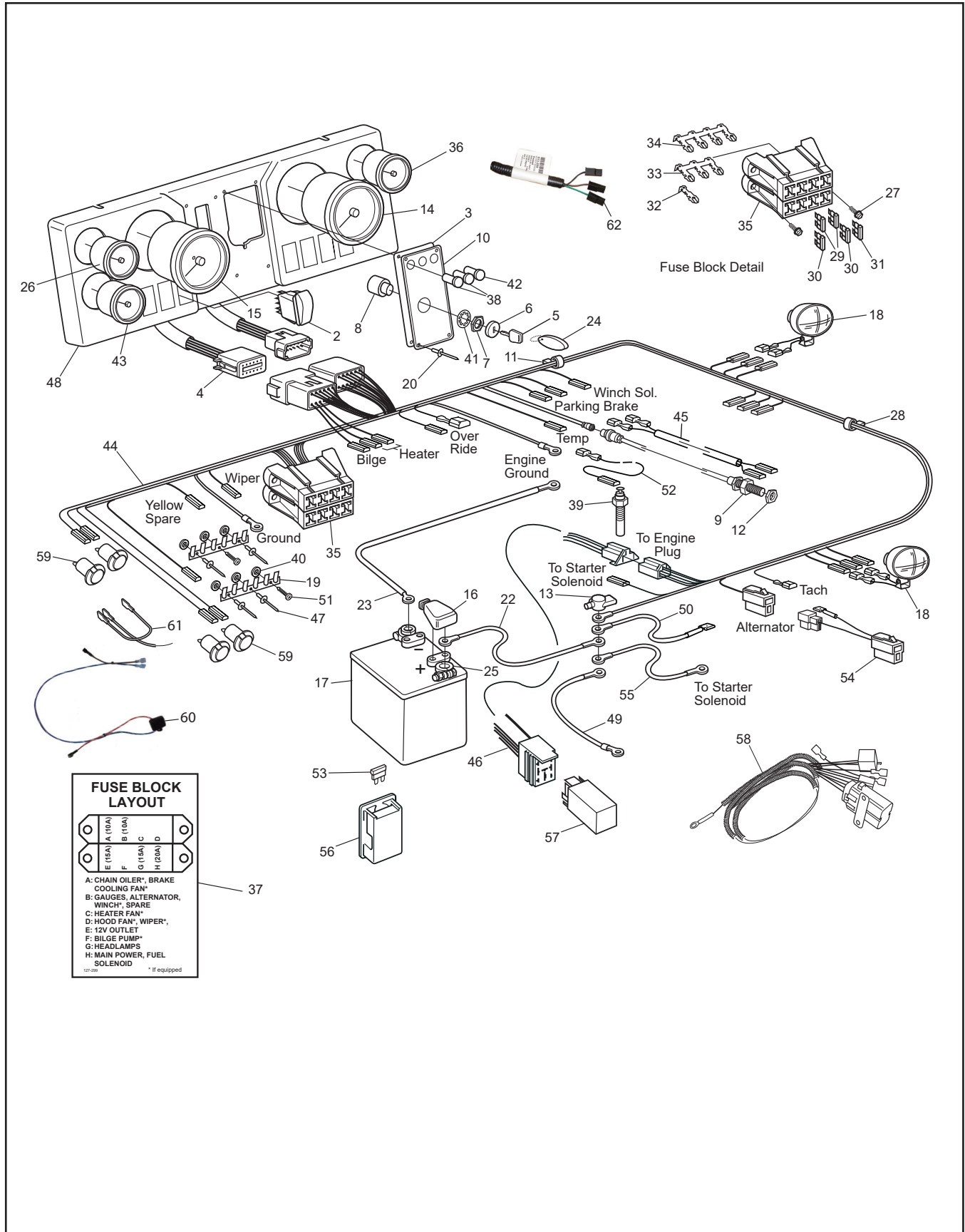

Ref.	Qty.	Part #	Description	Ref.	Qty.	Part #	Description
2	1	613-153	Switch, Light	47	2	120-15	Rivet - 1/8 x 7/16
3	1	127-234	Plate, Ignition - XT	48	1	613-180	Dash Asm, Panel Gauge Wire XT
4	1	613-181	Wire Harness, Gauges XT	49	1	613-214	Wire Harness, Glow Fuse - XTD
5	2	127-108	Key, Molded	50	1	613-215	Wire Harness, Alt. Out - XTD
6	1	127-107	Bezel - Cover, Nut	51	1	112-102	Screw, Self Drill 12-14 x 3/4"
7	1	127-106	Nut, Flanged - Plastic	52	1	613-219	Wire Harness, Eng Temp - XTD
8	1	127-105	Switch - Ignition	53	1	118-76	Fuse, 50A, Maxi
9	1		Sensor, Speedo Pickup	54	1	613-213	Wire Harness, Alternator - XTD
10	1	127-290	Label, Ignition - XTD	55	1	613-216	Wire Harness, Starter - XTD
11	4	127-24	Clamp, Nylon - 1" ID	56	1	613-218	Holder, Fuse, Maxi
12	1	117-87	Nut, M12 x 1.25, Zn	57	1	ED0021931340-S	Relay
13	1	613-124	Insulator, 2 Way w/cap, Red	58	1	613-260	Harness, Neutral Bypass Relay
14	1	613-184	Gauge, Tachometer - XT	59	2	118-80	Outlet, 12 Volt & Twin USB
15	1	613-185	Gauge, Speedometer 0-45K XT	60	1	613-231	Wire Harness, USB
16	1	127-55	Cap, Battery Terminal - Red	61	1	613-243	Harness, USB, XT
17	1	126-108	Battery, 12V, XT	62	1	613-259	Harness, Winch Diode
18	2	613-175	Headlight, 12V Bottom Mnt - XT				
19	2	613-37	Terminal Strip, Ground				
20	4	120-33	Rivet, 1/8 x 1/2 Black				
21	1	613-46	Insulator, Terminal (2 ga.)				
22	1	613-197	Wire, Positive Battery XT				
23	1	613-198	Wire, Negative Battery XT				
24	1	681-00	FOB, Key - Floating				
25	2	127-56	Terminal, Battery Post				
26	1	613-186	Gauge, Coolant Temp XT				
27	2	112-51	Screw, IHWH T/C #10-24 x 5/8				
28	4	126-93	Clamp, Nylon Wire - 1/2" ID				
29	2	118-52	Fuse, 10A 2 Prong (AT010)				
30	2	118-49	Fuse, 15A 2 Prong (AT015)				
31	1	118-53	Fuse, 20A 2 Prong (AT020)				
32	9	118-62	Terminal - Fuse, single				
33	1	118-63	Terminal - Fuse, triple				
34	1	118-61	Terminal - Fuse, quad				
35	2	118-60	Block - Fuse, 8 position (4 fuse)				
36	1	613-187	Gauge, Battery Voltage XT				
37	1	127-143	Label, Fuse Panel - XT				
38	2	613-191	Light, Indicator Red				
39	1	119-11	Sender, Coolant Temp, VDO				
40	6	120-04	Washer .19 x .50 x.08 Zn				
41	1	114-26	Lockwasher, 5/8 Int. Tooth				
42	1	613-192	Light, Indicator Amber				
43	1	613-199	Gauge, Fuel Level XT				
44	1	613-176	Wire Harness, Kohler EFI XT				
45	1	613-177	Wire Harness, Park Brake XT				
46	1	613-212	Wire Harness, KDW1003- XTD				

13.0 Electrical System

Conquest Parts Manual

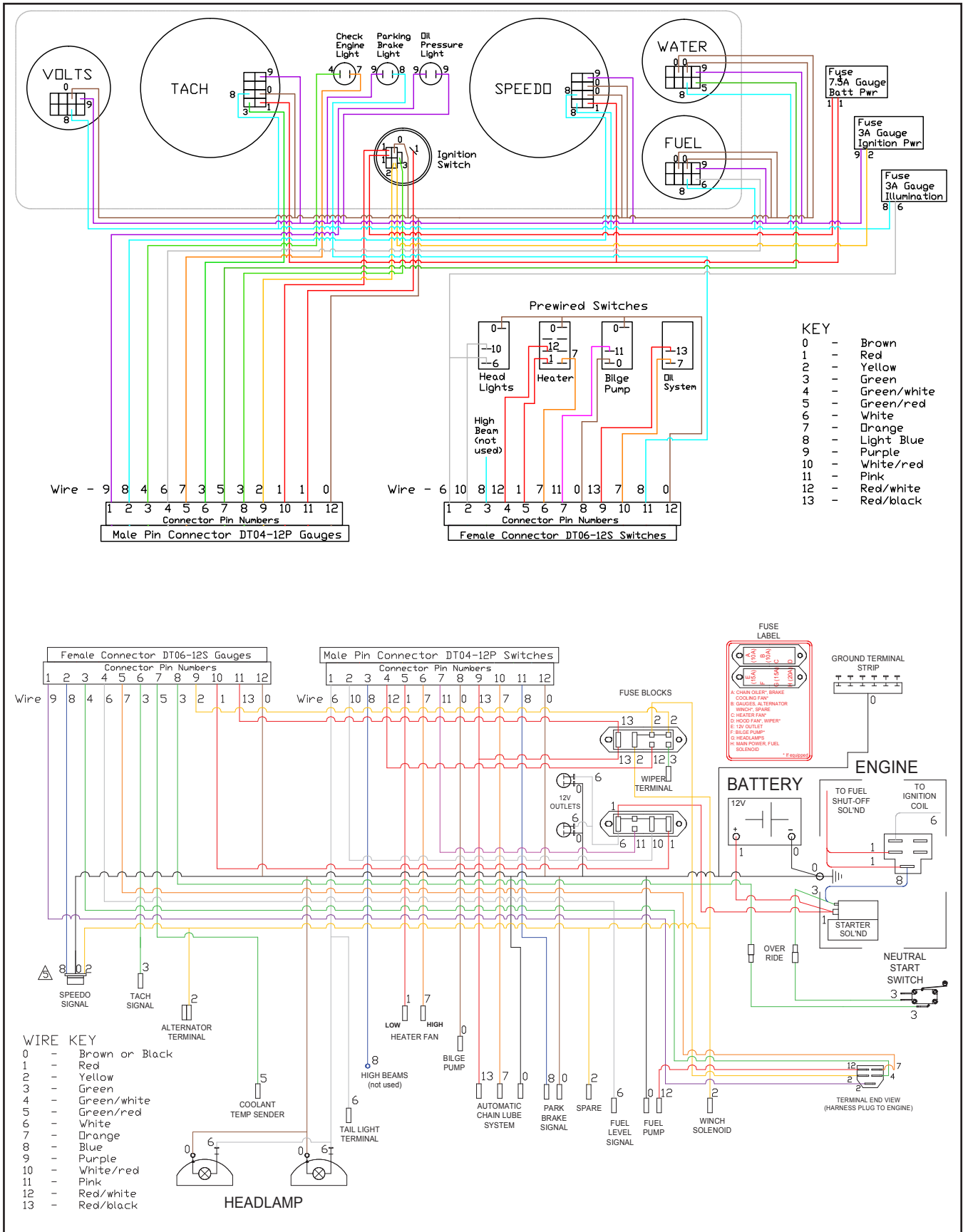

14.0 Outfitter Trim Package

Conquest Parts Manual

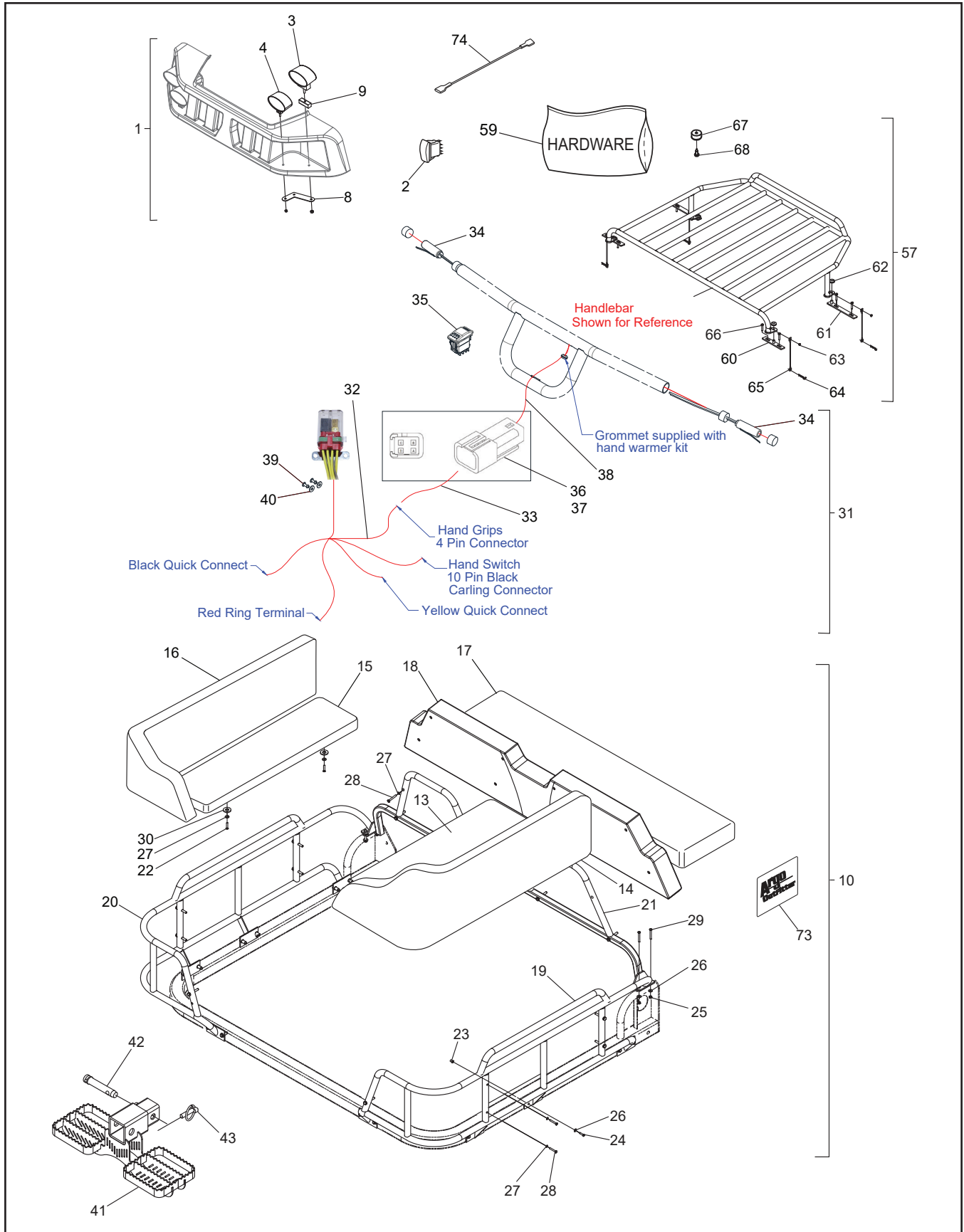

Ref.	Qty.	Part #	Description	Ref.	Qty.	Part #	Description
1	1	958-275	ACC, Outfitter Lighting (incl. Ref. 2-9, & 31)	57	1	958-222	Hood Rack, XT (incl. Ref. 58-68)
2	1	613-77	Switch, Light Hi/Low	58	1	958-223	Wldt, Hood Rack, XT
3	2	613-234	Light, Cree LED Work, 20W	59	1	958-222HDW	Acc. Hood Rack, XT Hardware
4	2	613-235	Light, Led Work, 24W	60	2	958-268	Wldt, Hood Rack Mount - Rear
7	7	112-139	OHPS T/S #4x5/8 Black Zn	61	2	958-269	Wldt, Hood Rack Mount - Front
8	2	958-273	Bracket, Headlight, XT	62	4	127-132	Grommet, Rubber - 1/2" ID
9	2	958-270	Plastic, Headlight Spcr, Outftr	63	4	120-31	Rivet, 3/16" x 1/4", Open End
10	1	720-07	Seat Group, Outfitter, CNQ (incl. ref. 13-30)	64	4	100-16	Clip, Hitch Pin 1.625 Zn
13	1	850-419	Seat, RH Rear Bench, Outftr	65	4	104-80	Lanyard, 6" Loop, W/Tab
14	1	850-417	Seat, RH Rear Back Rest, Outftr	66	8	112-176	HHCS M6x1,0x30mm Zn
15	1	850-418	Seat, LH Rear Bench, Outftr	67	2	126-102	Bumper, Recessed Hole
16	1	850-416	Seat, LH Rear Back Rest, Outftr	68	2	103-48	T/S Pan Hd Phil #10x5/8 A Blk
17	1	608-88CF	Seat, ASM, Bench-Carb Fib.	72	2	638-08	Hull Fitting 3/4" *Bilge Pump Acc*
18	1	850-415	Seat, Frnt Back Rest, Deluxe	73	2	958-266	Nameplate, Argo Outfitter
19	1	958-263	Wldt, RH Rear Seat Frm, Outftr	74	1	613-258	Wire, Fog Light Acc
20	1	958-257	Wldt, LH Rear Seat Frm, Outftr	Outfitter trim package also includes the following standard Argo accessories: 622-145 Winch Kit 958-165 Brush Guard 958-71 Bilge Pump 850-228-1 Chain Oiler			
21	1	958-337	Frame, Conquest Back Rest				
22	4	103-08	HHCS-1/4-20x1.0 Gr5				
23	16	117-79	Insert, M6x1,0 -10 mm OD				
24	16	112-97	HHCS M6x1,0x25mm Zn				
25	4	112-115	Locknut, Nylon M6x1 Zn				
26	38	108-08	Washer .28x.62x.07 Zn				
27	38	108-03	Lockwasher 1/4 Split Ring Zn				
28	14	112-297	HHCS 1/4-20 x 1.75 Zn				
29	4	112-299	HHCS M6x1,0x50mm Zn				
30	4	108-01	Washer, Fender 1/4x1.25 OD				
31	1	850-426	Acc, Heated Hand Grips (Ref. 32-40)- No Longer Avail.				
32	1	613-270	Harness, Heated Grips Acc.				
33	1	613-271	Harness, Hand Grip Ext.				
34	1	613-272	Warmers, Hand w/Term (NLA)				
35	1	613-273	Switch, Hand Warmer, Illum.				
36	1	613-274-29	Connector, mp150 m, 4P, Blk				
37	1	613-274-51	TPA, mp150 m, 4P				
38	2 ft	118-84-03	Tubing, PVC Black, 5/16				
39	2	120-11	Rivet, 5/32 x .157-.472				
40	2	120-05	Washer, .19x.50x.04				
	1	958-240	Acc, Rear Step, XT (incl. Ref. 41-43)				
41	1	958-243	Wldt, Rear Step, XT				
42	1	104-13	Pin, Top Link				
43	1	104-11	Pin Lynch Locking-Ring				

15.0 XT-L Trim Package

Conquest Parts Manual

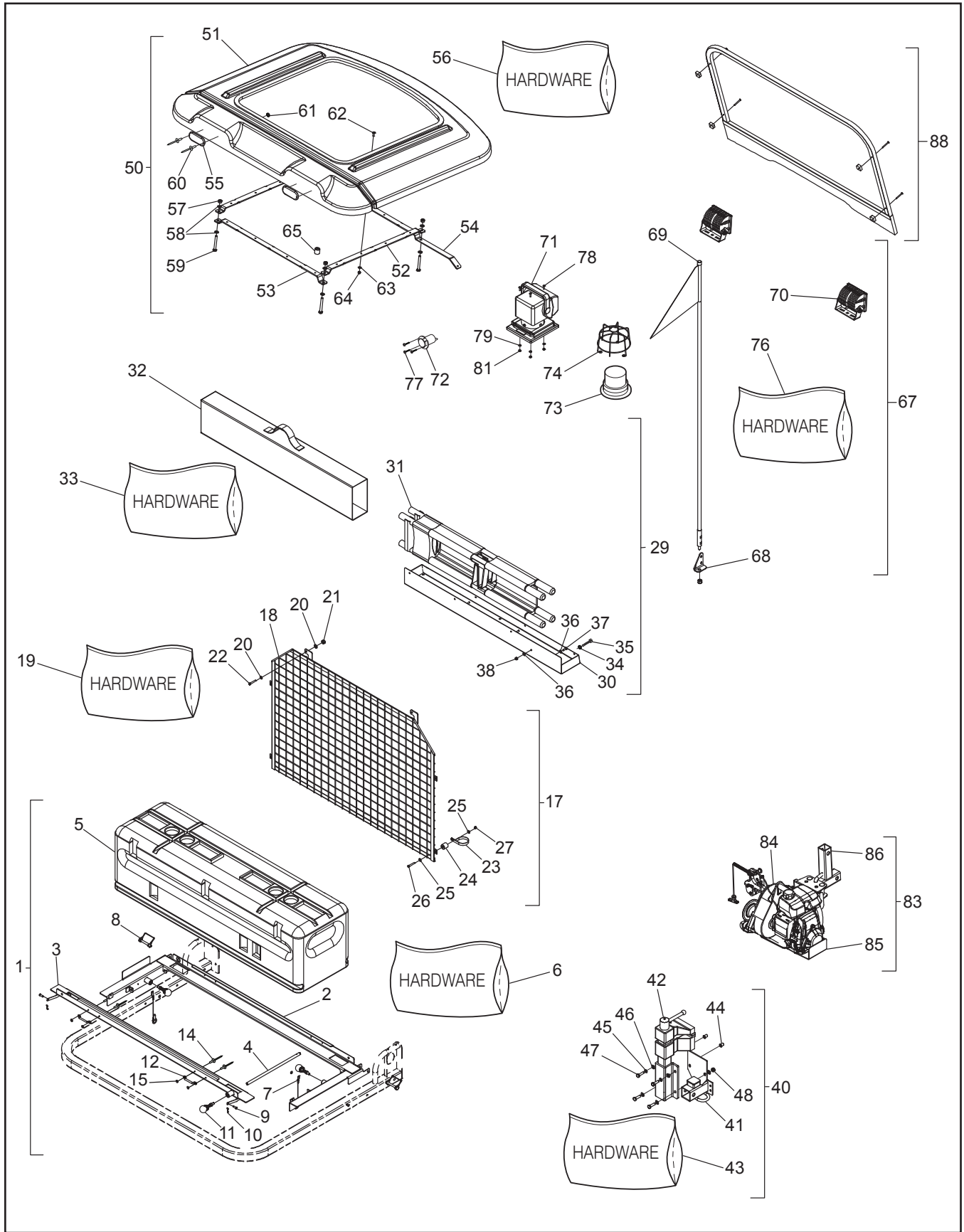

Conquest Parts Manual

15.0 XT-L Trim Package

Ref.	Qty.	Part #	Description
1	1	958-300	Acc, Rear Rack, XT
2	1	958-302	Wldt, Rear Rack, XT
3	1	958-303	Wldt, Rack Rail, XT
4	1	958-321	Rod, Rear Rack, Lineman
5	1	958-281	Tool Box, Lineman
6	1	958-300HDW	Acc, Rear Rack, Hardware
7	2	104-86	Pin, Quick Release 3/8x.5 W/Lanyard
8	2	104-45	Pin, Safety, 3/8x2-1/4
9	2	104-28	Pin, Clevis 1/4 x.780" Zn
10	2	104-29	Pin, Cotter 1/16x3/4 Zn
11	3	104-70	Pin, 3/8", Weld-In, Spring LD
12	4	808-151	Loop, Footman 2" Zn
13	2	850-304	Restraint, Two 5ft Cot Straps
14	10	120-13	Rivet - 3/16 x 3/4 Black
15	10	120-04	Washer .19x.50x.08 Zn
17	1	958-322	Acc, Rear Screen, Lineman
18	1	958-310	Wldt, Rear Screen, Lineman
19	1	958-322HDW	Acc, Rear Screen, Hardware
20	4	108-15	Washer .42x.81x.05 Zn
21	2	117-60	Locknut, Nyloc M10x1.5mm Zn
22	2	112-93	HHCS M10x1,5x25mm
23	4	127-276	Clamp, Loop, 2 1/4"-XT
24	4	126-120	Bumper, Rubber, 1" x 1"
25	8	108-08	Washer .28x.62x.07 Zn
26	4	112-98	HHCS M6x1x40mm Zn
27	4	112-115	Locknut, Nylon M6x1 Zn
29	1	958-318	Acc, Stretcher, Lineman
30	1	958-294	Stretcher Tray, XT
31	1	958-279	Stretcher, Ferno
32	1	958-280	Stretcher, Bag, Ferno
33	1	958-318HDW	Acc, Stretcher, Lineman, Hardware
34	4	108-03	Lockwasher 1/4 Split Ring Zn
35	4	112-297	HHCS 1/4-20 x 1.75 Full Thread
36	8	108-08	Washer .28x.62x.07 Zn
37	4	112-04	HHCS 1/4-20x3/4 Gr5 Zn
38	4	117-27	Locknut, Nylon 1/4-20 Zn
40	1	958-319	Acc, Vise, Lineman
41	1	958-291	Wldt, Lineman Hitch Receiver
42	1	958-278	Vise, Wilton, Lineman
43	1	958-319HDW	Acc, Vise, Lineman, Hardware
44	2	117-70	Insert, M10x1.5-13.5Mm OD
45	2	108-67	Lockwasher M10 Split-Ring Zn
46	6	108-15	Washer .42x.81x.05 Zn
47	4	112-133	HHCS M10x1,5x35mm Zn
48	2	117-60	Locknut, Nyloc M10x1.5mm Zn

Ref.	Qty.	Part #	Description
50	1	958-317	Acc, Roof, Lineman
51	1	958-282	Roof, Clear View, Lineman
52	2	958-293	Brkt, Roof Support, XT
53	1	958-107	Brkt, Rr Mnt - XT Hard Top
54	1	958-106	Brkt, Fr Mnt - XT Hard Top
55	2	127-01	Reflector, Red
56	1	958-317HDW	Acc, Roof, Lineman, Hardware
57	4	117-60	Locknut, Nyloc M10x1.5mm Zn
58	8	108-101	Washer, 0.41X0.79x0.08 Zn
59	4	112-120	HHCS M10x1,5x80mm Zn
60	4	120-13	Rivet - 3/16 x 3/4 Black
61	4	120-05	Washer .19x.50x.04 Zn
62	18	103-73	THMS, Phil 1/4-20x.75 Zn
63	18	108-08	Washer .28x.62x.07 Zn
64	18	117-27	Locknut, Nylon 1/4-20 Zn
65	1	126-120	Bumper, Rubber, 1" x 1"
67	1	958-316*	Acc, Lighting, Lineman
68	1		Brkt, Whip Light, Lineman
69	1	613-256	LED Whip
70	2	613-247	Light, Led Headlight, XT
71	1	613-248	Light, Spot, Lineman
72	1	613-90	Outlet, 12 Volt DC
73	1	613-268	Light, Strobe, Amber
74	1	613-275	Strobe, Light Guard
75	1	613-257	Wire Harness, Lights, Lineman
76	1	958-316HDW	Acc, Lighting, Lineman, Hardware
77	3	112-139	OHPS T/S #4x5/8 Black Zn
78	2	103-25	PHMS 10-24x3/4 Zn
79	3	120-04	Washer .19x.50x.08 Zn
81	3	117-10	Locknut, 10-24 N/I Zn
83	1	958-320*	Acc, Capstan Winch, Lineman
84	1	958-276	Winch Acc, Capstan, Lineman
85	1	958-277	Winch Acc, Support, Capstan
86	1	958-286	Wldt, Capstan Receiver, XT
87	1	622-135	Acc, Rear Receiver Winch
88	1	958-90	Windshield Asm, XT
89	1	958-130	Acc, Windshield XT Wiper Washer

XT-L trim package also includes the following standard Argo accessories:
 622-145, Winch Kit 958-165 Brush Guard
 956-15, 2 Pers. ROPS 958-71 Bilge Pump
 958-322 Mesh-ROPS 850-228-1 Chain Oiler
 613-247 LED Headlight

* Available but not included.

ARGO Products Manufactured by:

Ontario Drive & Gear Limited

220 Bergey Court

New Hamburg, Ontario

Canada N3A 2J5

Phone: (519) 662-2840

Fax: (519) 662-2421

www.argoxtv.com

ODG *Dedicated to quality and performance*